

# SKID STEER LOADER



## Specifications

Operating Weight	8600 lbs (3900 kg)
Horsepower	83 hp (62 kw)
Height to Bucket Pin	129 in (3277 mm)
Dump Reach at Bucket Discharge	30 in (762 mm)

## Features

- ▶ Vertical lift path ideal for loading and pick and carry applications
- ▶ Robust chassis with 10.5" of ground clearance\* and a 25.5° angle of departure, able to work on soft, uneven terrain and slopes where other skid steers can't
- ▶ Easy operation with standard pilot-operated joystick controls and comfortable operator station
- ▶ Standard mechanical faced axle seals protect bearings, reducing maintenance and downtime
- ▶ Tilt-up ROPS and tilt-out coolers make daily maintenance checks quick and easy

*\* Unloaded*

**WORKS FOR YOU.™**

# SPECIFICATIONS

## OPERATING SPECIFICATIONS

Loader Arms	Vertical
Operating Weight	8600 lbs (3900 kg)
Shipping Weight	7515 lbs (3409 kg)
Tipping Load	6000 lbs (2721 kg)
Rated Operating Capacity	3000 lbs (1361 kg)
Maximum Travel Speed	8.5 mph (13.6 kph)
Maximum Travel Speed (with optional 2-speed transmission)	12 mph (19 kph)
Height to Bucket Pin	129 in (3277 mm)
Dump Height at Bucket Discharge	97 in (2464 mm)
Dump Reach at Bucket Discharge	30 in (762 mm)
Max Dump Angle at Full Height	52°
Bucket Breakout Force	5878 lbs (2666 kg)
Arm Lifting Force	5871 lbs (2663 kg)
Rear Angle of Departure	25.5°
Bucket Roll Back at Ground Level	30°
Ground Clearance	
Loaded	10.5 in (266.7 mm)
Unloaded	10 in (254 mm)
Overall Length with Bucket	144 in (3657 mm)

## ENGINE

Type	Diesel, 4-cylinder, turbocharged
Model	Perkins 804D-33T
Displacement	201 in <sup>3</sup> (3.3 L)
Gross Horsepower Rating @ 2500 rpm	83 hp (62 kw)
Torque Peak	195.5 ft-lb (265 Nm)
Cooling System	Engine-driven fan and coolant/anti-freeze filled radiator
Engine Block Heater	Standard, AC plug-in type
Intake Air Cleaner	Dual Stage
Emissions Controls	Meets all U.S. EPA Interim Tier 3 Standards

## DRIVE TRAIN

Drive System	Hydrostatic
Chain Case	Bow Tie Drive System
Chain Size	100 ANSI Chain
Wheel Size	12 X 16.5
Width Over Tires	72 in (1829 mm)
Tractive Effort	8700 lbs (3946 kg)
Wheel Base	49 in (1244 mm)



## SERVICE CAPACITIES

Fuel Tank	30 gal (113 L)
Hydraulic Tank	10 gal (38 L)
Engine Oil (including filter)	9 quarts (8.52 L)

## AUXILIARY HYDRAULIC SYSTEM

Max System Pressure	3335 psi (230 bar)
Controls	Pilot Hydraulic Joystick
Couplers	3/4" Flat Faced
Auxiliary Pump Flow	28 gpm (106 lpm)
Optional Flow	42 gpm (159 lpm)

## ELECTRICAL SYSTEM

Normal Charge	12V
Battery	925 CCA
Charging System	90 amp alternator
Outlets	1-12V port inside operator station

## OPERATOR STATION

Seat: Standard seat with an optional adjustable suspension seat available.	
Loader Control: Right-hand pilot hydraulic joystick controls loader lift/tilt, with intermittent control of auxiliary hydraulics.	
Drive Control: Left-hand pilot hydraulic joystick controls machine speed and direction.	
Engine Speed Control	Foot Throttle
Indicators/Gauges	Fuel Tachometer Engine Temperature Hour Meter Battery Two speed Oil Level Hydraulic Temperature Water Temperature
ROPS/FOPS	Meets ISO 3471:2008 ISO6683:2005 ISO 3449:2005 Level 1
Illumination	2 forward facing lights 2 rear facing lights

**DIMENSIONS: GENERAL PURPOSE BUCKET**

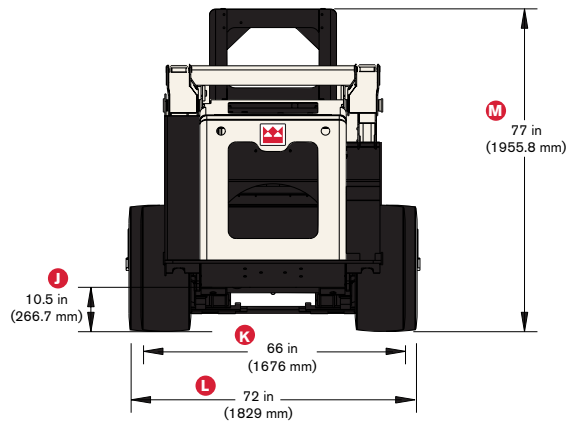
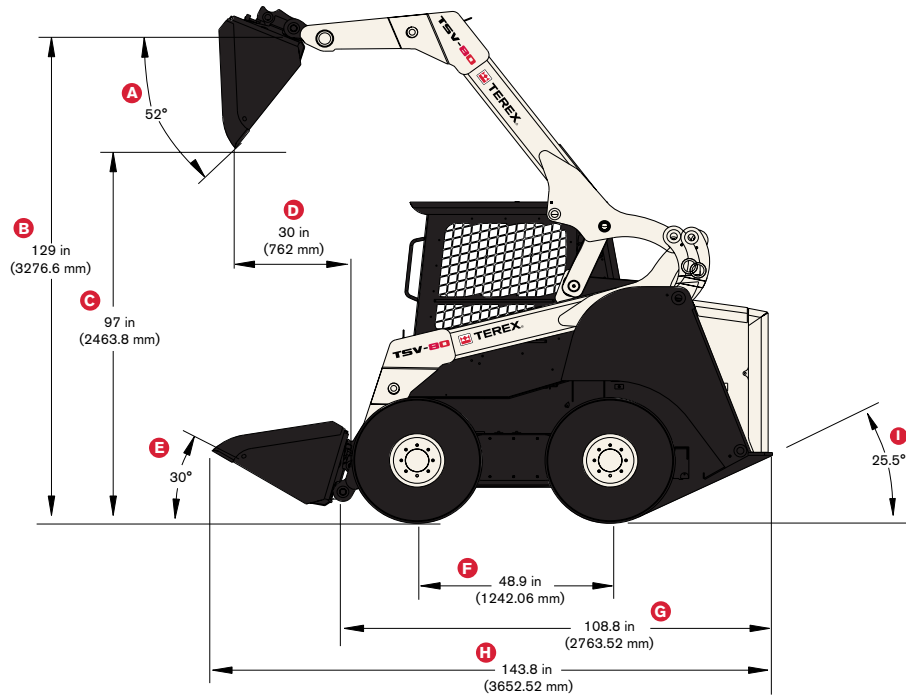

**MEASUREMENTS**

A	Dump Angle	H	Overall Length with Bucket
B	Height to Hinge Pin	I	Rear Angle of Departure
C	Height to Bucket Discharge	J	Unloaded Ground Clearance [ 10 in (254 mm) Loaded]
D	Reach at Full Height	K	Width Between Tires with Rims Reversed
E	Bucket Rollback at Ground Level	L	Width Between Tires
F	Wheel Base	M	Overall Height to Top of ROPS
G	Overall Length without Bucket		

# OPTIONAL EQUIPMENT

## OPTIONAL ATTACHMENTS

Auger Drive And Bits	Brush Cutter, Rotary	Snow Blower
Backhoe	Dozer Blade	Stump Grinder
Broom, Rotary	Grapple Bucket	Trencher
Bucket, General Purpose	Pallet Forks	Vibratory Roller
Bucket, Light Material	Power Box Rake	Eliminator Rake
Bucket, Multi-Purpose	Snow Blade	

*Additional attachments available upon request.*

[www.terex.com](http://www.terex.com)

Effective Date: April 2011. Product specifications and prices are subject to change without notice or obligation. The photographs and/or drawings in this document are for illustrative purposes only. Refer to the appropriate Operator's Manual for instructions on the proper use of this equipment. Failure to follow the appropriate Operator's Manual when using our equipment or to otherwise act irresponsibly may result in serious injury or death. The only warranty applicable to our equipment is the standard written warranty applicable to the particular product and sale and Terex makes no other warranty, express or implied. Products and services listed may be trademarks, service marks, or trade names of Terex Corporation and/or its subsidiaries in the USA and other countries. All rights are reserved. Terex is a registered trademark of Terex Corporation in the USA and many other countries. © 2010 Terex Corporation.

Terex Construction 8800 Rostin Road, Southaven, MS 38671 USA  
Tel +1 (888) 90-TEREX [www.terex.com](http://www.terex.com)



**WORKS FOR YOU.™**

TSV80 0411 PN 280232