

TECHNICAL SPECIFICATIONS

Overall Specification	Model	SYG5260THB 37
Length		11700 mm
Width		2500 mm
Height		3920 mm
Total weight		28800 kg

Note: The overall specifications are based on Chassis Model BENZ Actros 3341.
 Dimensions will vary with different truck makes, models and specifications.
 Weights are approximate and include pump, boom, truck, full hydraulic oil, driver and some fuel.
 Varies with options selected.

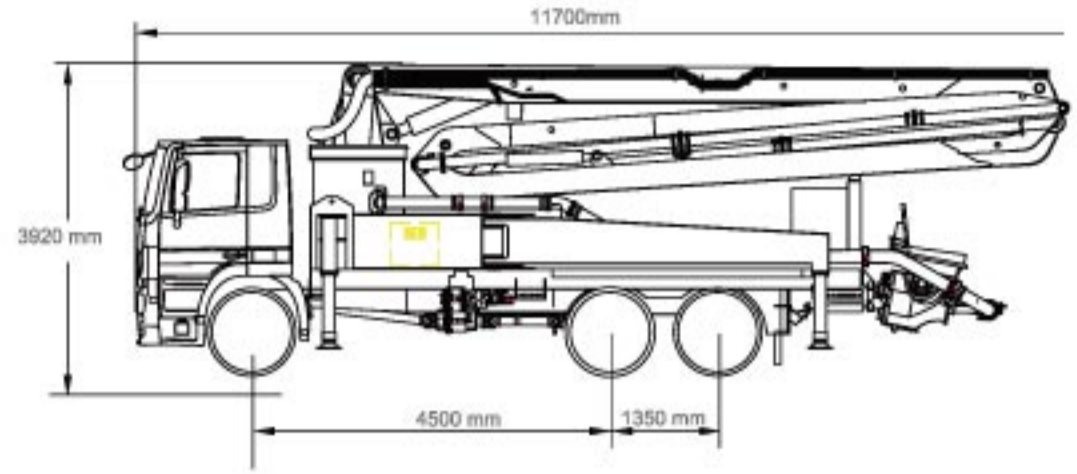

Boom & Outrigger Specification		
Vertical reach		37.0 m
Horizontal reach		33.0 m
Reach depth		21.3 m
Minimum unfolding reach		8.3 m
Arm1	Length	8700 mm
	Angle	90°
Arm2	Length	7860 mm
	Angle	180°
Arm3	Length	8050 mm
	Angle	180°
Arm4	Length	8390 mm
	Angle	245°
Arm5	Length	-
	Angle	-
Slewing circle		±360°
Outrigger spread L-R (front)		6200 mm
Outrigger spread L-R (rear)		7160 mm
Outrigger spread width (LH)		6630 mm
Outrigger spread width (RH)		6630 mm

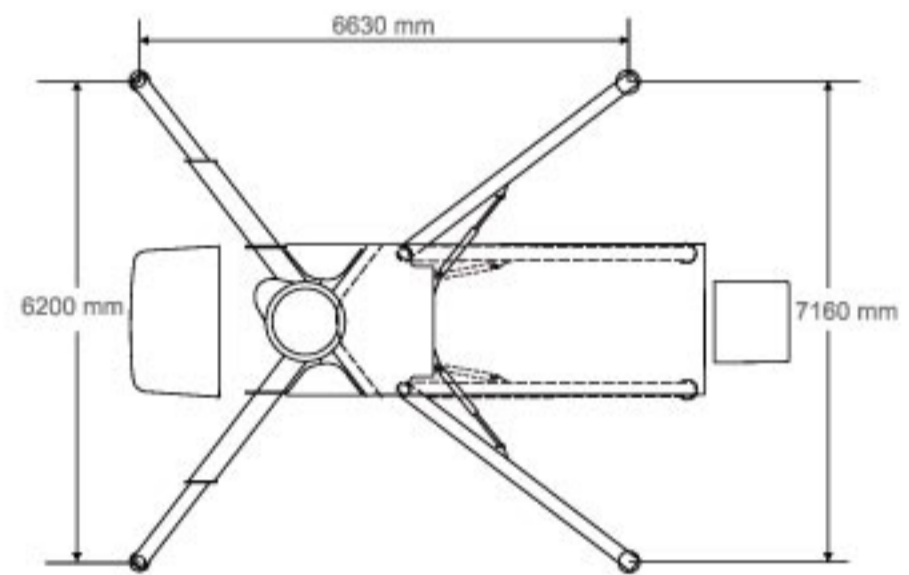

Pumping System Specification		
Output	Low pressure	140 m³/h
	High pressure	100 m³/h
Pressure	Low pressure	8.3 MPa
	High pressure	12 MPa
Max. strokes	Low pressure	22 times/min
	High pressure	15.5 times/min
Delivery cylinder diameter		260 mm
Delivery cylinder stroke		2000 mm
Hydraulic system		Open loop
Hydraulic system oil pressure		max 320 bar
Oil tank capacity		900 L
Water tank capacity		600 L
Pipeline size		125 mm
End hose length		3 m
End hose diameter		125 mm

