

Universal Loader **K3**

precise quickness
utmost stability
amazing power



Motor	Perkins Diesel engine 4-cylinder, water-cooled	36 2216	power kW (50PS) cm ³ cubic capacity
Lifting capacity		1600	kg
Tipping load	in driving direction, telescope retracted	1500	kg
Axle	telescopic front axle	124–187	cm width with standard tyres
Front loader	hydraulically telescopic lifting arm, lifting height up to	330	cm
Drive	infinitely variable, hydrostatic fourwheel drive	0–18	km/h
Traction hydraulics	Variable displacement axial piston pump with 4 wheel hub motors; planetary gear inside of wheel hub with reduction ratio	170 01:01	L/min i
Hydr. system for tools	gear pump	72	L/min
Operat. pressure		180	bar
Operational brake system	acting on front and rear axles via hydrostatic travelling gear	×	
Parking brake	acting on rear axle	×	
Tyres	serial	10.0/75–15.3AS Total width 1,24–1,87 m	
Driver's seat	comfort seat with safety belt (each with integrated contact switch)	×	
Steering column	comfort steering column (vertically adjustable and inclinable) incl. working hour meter and fuel gauge	×	
Tool installation	serial quick-change plate Euronorm	×	
Counterweight	maximum	300	kg
Diesel tank	safety tank, integrated in frame	29	L
Oil tank	safety tank, integrated in frame	60	L
Unladen weight		2170	kg
Turning radius (internal)		1400	mm
Turning radius (external)		2560	mm
Weight of front axle		690	kg
Weight of rear axle		1480	kg

Dimensions are not binding. Changes in design may be subjects to alterations.

Practically for all Purposes

- Farming and Stockbreeding
- Local Use
- Industrial Use
- Warehousing and Logistics
- Horticulture and Landscape Architecture
- Building and Construction Industry



K3

Our new universal loader is unique concerning its loading capacity, stability and operating convenience. Thanks to its hydraulic telescope axle the universal loader can be driven through extremely narrow feed alleys. Within a few seconds the axle can be extended to 1.87 m thus providing utmost stability. The telescope arm of the loader reaches every corner; and the refined steering system enables precise and wobble-free loading even at great heights. The convincing drive system provides maximum power even under most delicate conditions, i.e. loading of manure or moving of earth. Full power is always applied to the respective wheel motors. Enormous lifting capacity and maximum safety and yet light enough to be manoeuvrable on slatted floors.



Stability

With the axle extended to a width of 1.87 m, the universal loader stands absolutely safe (tyres 10/15). If the underground is uneven, the centre of gravity is still within the wheel track thus preventing the universal loader from turning over. For this reason the universal loader can also be used in fields or forests. Within a few seconds it is possible to reduce the width to 1.24 m thus ensuring that the universal loader can be driven through narrow entrances and feed alleys.



Drive System

Hydraulic drive and wheel motors are designed in such a way that the entire power is translated fully from the respective driving axle to ground. In contrast to automotive drive systems engine speed and travelling speed are independent of each other. Therefore propulsion and lifting capacity can always be adjusted optimally at full engine power.

Lifting Capacity and Loading Range

Demands concerning lifting capacity and load height are increasingly high. This is no problem at all for the new OSTLER universal loader. Its telescope arm extends to 3.30 m thus enabling the driver to fill high fodder mixing trucks and dumpers and to extract bales in fodder storage rooms from undreamed-of heights. All that is achieved at maximum power thanks to optimal weight distribution and powerful cylinders.

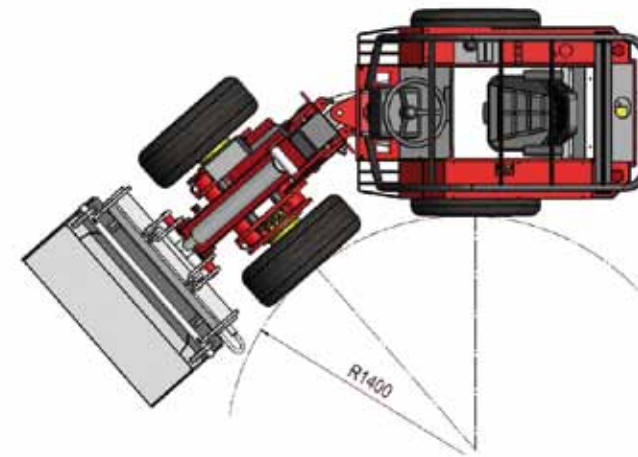

Steering System and Turning Radius

Despite its extraordinary lifting capacity, the new OSTLER universal loader can be steered easily thanks to its compact design. With an external turning radius of only 2,560 mm and a fine-tuned steering system it is easily manoeuvrable in narrow barns and stables. Furthermore lengthy loading activities with frequent changes of direction are no problem at all since starting of the loader is always a smooth process.

Special Equipment

- Hydraulic holding-down device with detachable tines
- Protection frame for holding-down device (for add. protection of driver in case of pallet work)
- Free control valve for add. tools
- Standard shovel 90 cm/200 l (with steel teeth)
- Shovel for heavy goods 120 cm/250 l (with steel teeth)
- Shovel for light goods 150 cm/450 l (without teeth)
- Pallet fork 90 or 125 cm
- Dung and grass fork with five tines (screwable)
- Snow and levelling scoop
- Earth drill
- Two work spotlights
- Lighting equipment for public roads (according to German Road Traffic Act)
- German road traffic expertise cabin



Thanks to the tool holding fixture, which meets the DGS Euro standard, commercially available tools can be used.



For working outdoors and optimized security the K3 is also available with a comfort cabin.



In-house development and production according to CE standards