



SKID STEER LOADERS

2700V



GET SOME VERTICAL FORCE

SPECIFICATIONS



VERTICAL-LIFT ▲ design delivers extended reach and 130-inch lift height, higher than any competitor in its weight class.



POWER UP ▲ with a 70.7-hp, turbocharged diesel engine with 206 ft.-lbs. of torque, and a rated operating capacity of 2,700 lbs.



WIDE-VIEW ▲ domed glass door option reduces glare and provides optimal visibility to the lift arm, attachment and front work area.



ENHANCE COMFORT ▲ and safety with a side-folding restraint bar and adjustable armrests.

PILOT-OPERATED ▲ joystick controls with adjustable handles, or pilot-operated hand/foot controls.

		2700V
DIMENSIONS	A. Overall Operating Height - Fully Raised (mm)	169.8" (4313)
	B. Height to Hinge Pin - Fully Raised (mm)	130.3" (3310)
	C. Overall Height to Top of ROPS (mm)	80.5" (2045)
	D. Ground Clearance to Chassis (mm)	8.0" (203)
	E. Overall Length with Bucket (mm)	149.2" (3790)
	F. Overall Length without Bucket (mm)	115" (2921)
	G. Wheelbase (mm)	49.8" (1265)
	H. Dump Reach at Full Height (mm)	34" (864)
	I. Bucket Rollback at Ground	28°
	J. Dump Angle	41°
	K. Overall Width (mm)	69.5" (1765)
	L. Bucket Width (mm)	70" (1778)
	M. Clearance Circle - Rear (mm)	65.5" (1664)
	N. Clearance Circle - Front without Bucket (mm)	56.3" (1430)
	O. Clearance Circle - Front with Bucket (mm)	93" (2362)
	P. Seat to Ground Height (mm)	40.2" (1021)
	Q. Rollback at Full Height	94°
	R. Dump Height (mm)	99" (2515)
	S. Departure Angle	27°
Standard Specification Tire Size		12.00-16.5 HD
ENGINE	Make	Yanmar
	Model	4TNV98T
	Power (kW) @ rpm	70.7 hp (52.7)
	Displacement (L)	203 cu.in. (3.3)
	Maximum Torque (Nm) @ rpm	206 ft.-lbs. (279.3)
HYDRAULIC SYSTEM	Auxiliary Hydraulics - Standard (L/min)	21.8 gpm (82.5)
	High-Flow Hydraulics - Optional (L/min)	36.3 gpm (137)
	System Relief Pressure (bar)	3300 psi (228)
	Reservoir Capacity (L)	10.5 gal. (40)
CAPACITIES / WEIGHT	Rated Operating Capacity ^A (kg)	2700 lbs. (1225)
	Fuel Tank (L)	20 gal. (76)
	Travel Speed - Maximum (km/hr)	7.4 mph (12)
	Travel Speed - Max. w/ 2-Speed Option (km/hr)	11.9 mph (19.2)
	Operating Weight ^B - Approximate (kg)	8100 lbs. (3674)

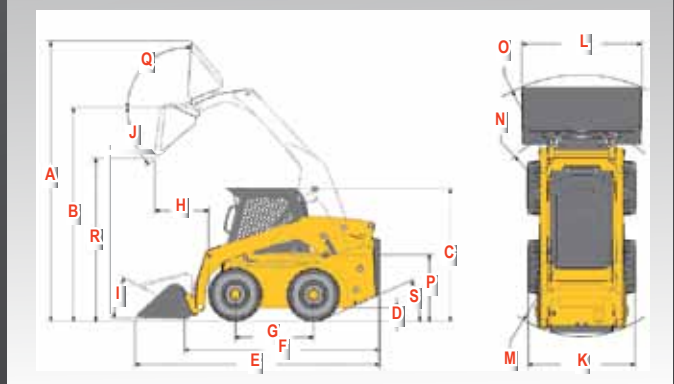

A Per SAE J818, SAE J732, and ISO 14397

B Unit weight with standard bucket, 175 lbs. (79 kg) operator and full fuel tank



For more information on Mustang Skid Steer Loaders and the rest of the Mustang equipment line, call our hotline at

1-800-628-0491

or visit mustangmfg.com

West Bend, WI USA
Tel: 262-334-9461
Fax: 262-338-7517