

Mecalac

FRONT LOADER **AF 1050**



> Experience of your worksite

FRONT LOADER

AF 1050

LET'S HAVE A LOOK

- **48 kW / 65 hp at 2600 rpm**
- **Tipping load, max. steered: 3800 kg**
- **Dumping height: 2820 mm**



Increase of lifting power due to compensation cylinder by 20%



Optimum front and rear view due to monoboom and compact rear end

**Mecalac
Single
Arm
Power**

Monoboom with powerful, protected Z-Kinematics and parallel guidance

Brand compatible quick-coupler

Wide range of attachments



AT YOUR ADVANTAGES

Mecalac
Panorama
Cab



Intelligent
cooling concept



2 doors for easy access on both sides



Mecalac
Four
Wheel
Steering

Four-wheel steering
for maximum
stability and best
manoeuvrability

FRONT LOADER
AF 1050

POWERFUL AT WORK



The slender monoboom allows for an optimum view on the attachments. Cylinders, hoses and electrics are protected inside the boom. This extends the life of components and reduces maintenance and repair costs.

The "Boost" increases the lifting capacity during the loading process. This ensures always a maximum bucket filling without any increase in fuel consumption. Thus the productivity of the machine is enhanced significantly.

The Z-kinematics ensures greater breakout force and perfect parallel guidance when using the pallet fork.



MANOEUVRABLE AND COMPACT



The four-wheel steering provides maximum stability and maneuverability in any working situation.

Large glass panels in the spacious panoramic cabin allow optimum visibility on the work environment. 2 large doors provide safe entry and exit on both sides of the cabin even in confined spaces.

The ergonomic, hydraulically assisted joystick has an integrated control for the auxiliary hydraulic. It can also be extended depending on customer requirements, for example electro-proportional.



Operation weight 5,800 kg
 Engine power: 48 kW
 Bucket capacity: 1.05 – 1.5 m³



Engine

Low noise, water-cooled 4 cylinder Cummins diesel engine (emissions acc. to EU 97/68), 4-stroke, direct fuel injection

Net power at: 65 hp
 acc. to SAE J 1995: 48 kW
 at: 2,600 min⁻¹
 Max. torque at: 1,600 min⁻¹
 acc. to SAE J 1995: 214 Nm
 Air intake filter: 2 level dry-air filter with safety cartridge
 Cooling system: thermo-controlled hydrostatic fan
 Electrical system:
 Operating voltage: 12 Volt
 Battery capacity: 88 Ah
 Alternator rating: 120 A 1680 Watt

Drive

Hydrostatic drive with automotive control, 2 stages for maximum propulsive force, shiftable under load, multifunctional lever (joystick) for drive and working hydraulics control

Axles: planetary axles with four-wheel steering for maximum manoeuvrability, oscillating rear axle with suspension
 Differential lock: self-locking differential in front axle
 Wheels: 14.5-20
 optional: 405/70 R20
 Speeds: Road gear: 0-20 km/h
 (optional: 30 or 40 km/h)
 Oscillation: max. oscillation angle +/- 10°

Brakes

Working brakes:

1. hydrostatic inching brake, acting on all 4 wheels
2. hydraulically operated disc brake, acting on all four wheels (30/40 km/h versions: oil-immersed multiple disc brake) on front axle, acting on all 4 wheels

Parking brake:

mechanical actuated disc brake on front axle (30/40 km/h versions: Spring loaded brake), acting on all 4 wheels

Steering

Hydrostatic four-wheel steering with 3 steering modes: four-wheel/rear axle and crab steer
 max. steering angle +/- 35°

Turning radius:
 Measured over rear 3710 mm
 Measured over bucket 4060 mm

- Comfortable panoramic driver's cabin with ROPS safety system
- Joystick controls
- Servo-assisted working hydraulics
- High-performance, power controlled, hydrostatic four-wheel drive
- Four-wheel steering system with automatic alignment

Hydraulic system

Single circuit working hydraulics with gear pump (lift/lower, tilt, accessories), and steering (via priority valve); three-way control valve with primary and secondary safeguards
 Performance max. at 2,600 min⁻¹: 84 l/min and 225 bar
 Floating position for boom cylinders

Cylinder:	2 lifting cylinders	90 Ø
	1 tilting cylinder	100 Ø
Cycle-times:	Lift (under load)	3.5 s
	Lower (w/o load)	2.5 s
	Crowd time (90°)	1.5 s
	Dump time (45°)	1.8 s

Performance data

Digging depth with standard bucket:	70 mm
Bucket position:	Crowd angle 45°
	Dump angle top 45°
	Dump angle max. 105°

Lifting force:	5,400 daN
Lifting force with boost :	6,500 daN
Breakout force:	4,900 daN
Thrust force:	4,650 daN

Tipping load:

Standard bucket, max. steered, straight	3,800 kg
---	----------

Payload:

on forks, max. steered, frontal, even terrain	2,500 kg
on forks, max. steered, frontal, even terrain*	2,870 kg

Tipping load according to ISO 14397
 Payload according to EN 474-3
 * Transport position 300 mm above ground

Chassis

Rigid single-component chassis for maximum stability, independent of steering position, in every terrain. Innovative **Booster** boom with protected, internal kinematics as well as collision save internal lines, hoses and electrics. Standard, brand compatible electrohydraulic quick-coupler with exact parallel guidance feature. The monoboom concept guarantees optimum visibility to attachments. Operator's cab with flexible four-point mountings for maximum driver comfort and minimum noise levels. The servo-assisted joystick controls are smooth, accurate and long lasting.

Filling capacities

Engine with filter	approx.	8.0 l
Fuel tank	approx.	130.0 l
Front axle total	approx.	11.0 l
Rear axle with gearbox	approx.	12.0 l
Hydraulic system with tank	approx.	134.0 l

- Planetary axles with self-locking differential on front axle
- Monoboom with Z-Kinematics
- Increase of lifting power by **Booster**-Kinematics
- Hydraulically controlled quick-coupler with electric safety feature
- Brand compatible quick-coupler
- Wide range of attachments

Standard features

Amply dimensioned ROPS panoramic comfort cabin with 2 lockable doors for easy entry from both sides. The large doors open through 180° within the contour of the loader and can be locked in 2 positions. Big, single piece floor mat for easy cleaning. Tinted windows, parallel guided windscreen wiper for maximum visibility, rear wiper, front and rear screen washing device, heatable rear window, 2 large fold away outside mirrors, tinted roof window, steering column is adjustable in height and inclination, ergonomically adjustable joystick, multiply adjustable driver's seat with armrest and mechanical, weight adjustable suspension and safety belt. Sun visor, heating and ventilation system with fresh air filter and recirculation air function. Interior light, 12 V socket, coat hook, storage pockets in the cabin, storage box with lid, lockable storage compartment at the chassis.

Central multifunctional display, symbolic displays and control lights, 2 driving lights on cabin roof, 2 working lights at monoboom, reversing lights, indicators, rear and brake lights, single key system. Brand compatible hydraulic quick-coupler with electric safety device, indicator for parallel position at monoboom, towing coupling, fastening and lifting points, 1st auxiliary hydraulics circuit integrated in the joystick.
 Color scheme: yellow, operator's cabin, axles and wheels grey

Optional equipment

30 or 40 km/h version, wide tyres, beacon light, interior mirror, acoustic back up alarm, FOPS grid for cabin roof, bucket protection cover compliant to road-safety standards, 2nd auxiliary hydraulics, permanent function for auxiliary hydraulics, high performance hydraulic, safety valves, boom suspension, bio-degradable oil fill for hydraulic system, radio, lifting height limiter, pressureless return line, inching speed, lockable differential on rear axle, air suspended drivers seat, air-conditioning system, immobilizer, heatable rear mirrors, sliding windows right and left, main battery switch, 2 working lights rear, towing coupling complying to road regulations, rear mounting bracket, special corrosion protection for salt applications.
 Attachments as per separate list as pallet fork, load hook etc.

Weight

Machine with quick-coupler and standard bucket 1.05 m ³ with teeth:	5,800 kg
--	----------

Measurements

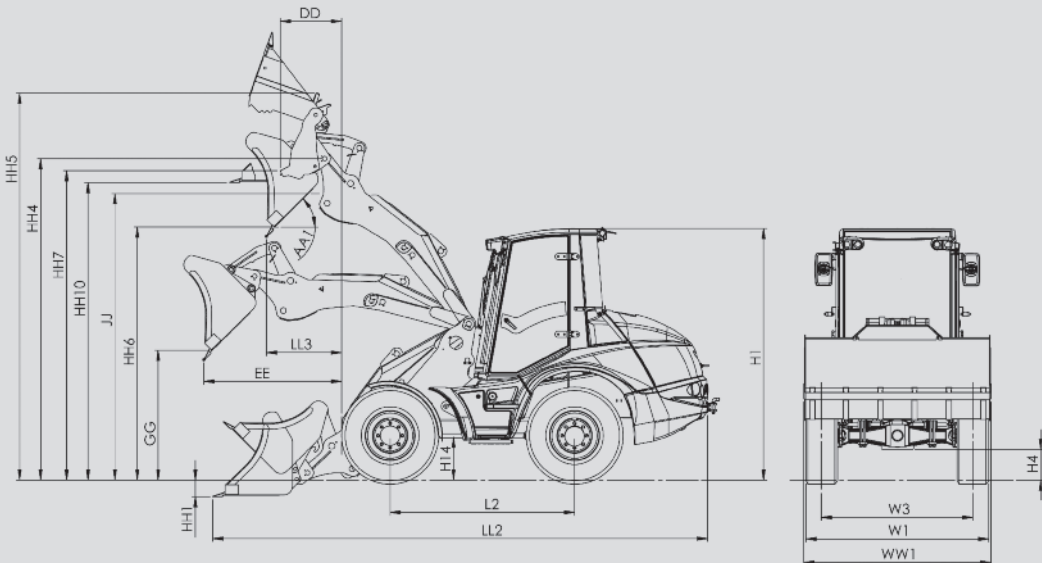

Buckets		
Standard	1.05 m ³	4 x 1 1.0 m ³
AA1	45°	45°
DD		570
EE	1580	1790
GG	890	780
H1	2830	2830
H14	420	420
H4	380	380
HH1	100	90
HH10	3455	3435
HH4	3650	3650
HH5	4590	4530
HH6	2850	2810
HH7		3390
JJ	2920	2920
L2	2085	2085
LL2	6030	6070
LL3	720	720
W1	1990	1990
W3	1660	1660
WW1	2100	2100

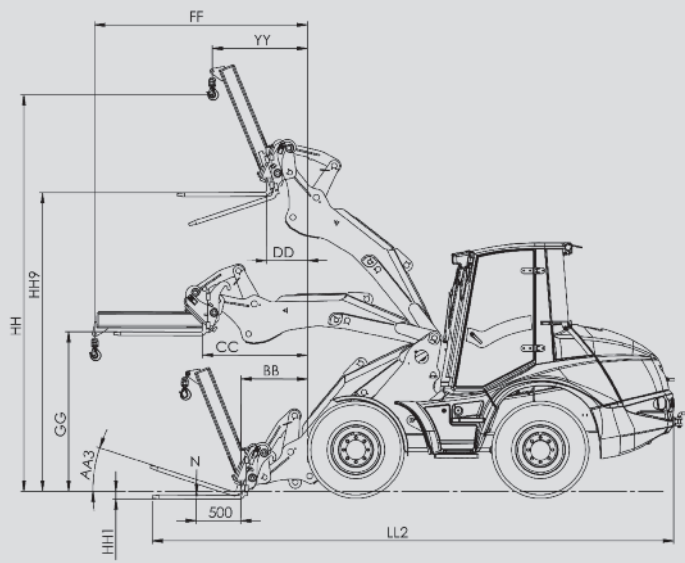

	Forks	Load hook
AA3	18°	
BB	850	
CC	1300	
DD	440	
FF		2730
YY		1220
GG	1470	
HH1	120	
HH		4450
HH9	3340	
LL2	6050	

Range of attachments

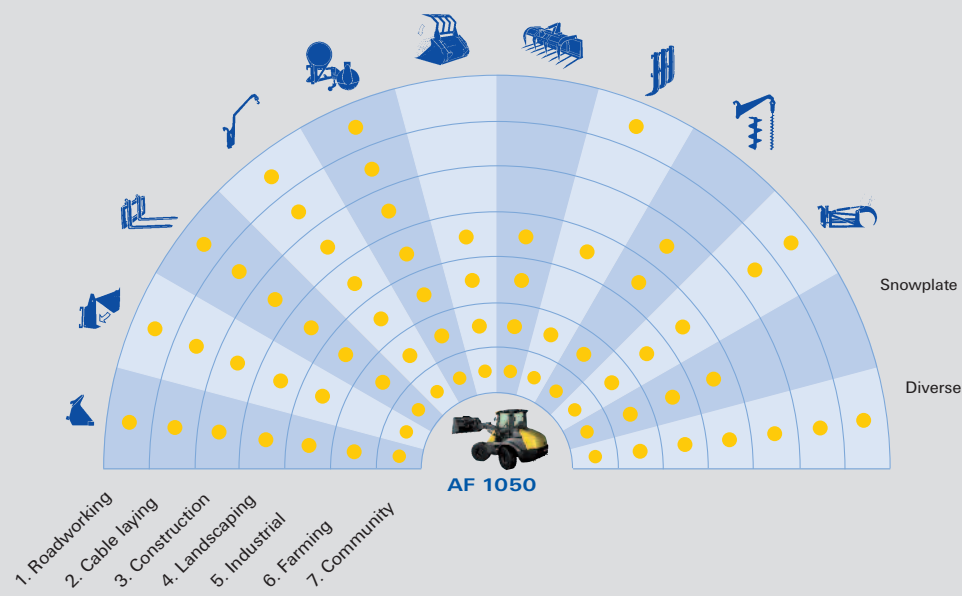

All data based on standard tyres. Technical data are non-committal and are subject to constructional modifications!



For decades we develop and produce high quality and innovative wheel loaders in Büdelsdorf in northern Germany. With our articulated loaders, four-wheel steered front loaders and four-wheel steered swing loaders, we are the world's only manufacturer to offer all steering concepts. Our four-wheel-steered swing loaders stand as the world's technologically most innovative wheel loaders.



Your Local Dealer

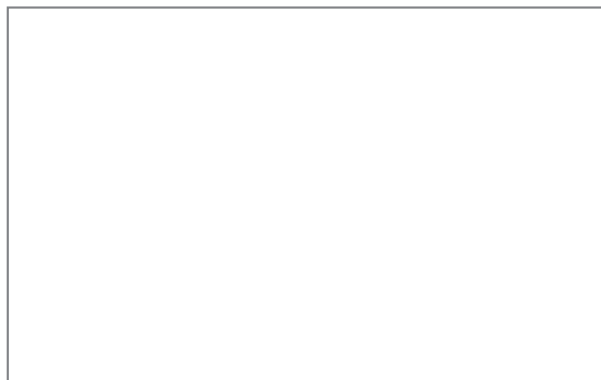

Mecalac

MECALAC BAUMASCHINEN GMBH · Am Friedrichsbrunnen 2 · D-24782 Büdelsdorf
Phone +49 (0) 43 31/3 51-319 · Fax +49 (0) 43 31/3 51-470 · info@mecalac.de · www.mecalac.com
A COMPANY OF GROUPE MECALAC S.A.