

# Articulated Dump Truck

**TA 230**  
Litronic®

Empty Vehicle Weight:	24,400 kg
Engine Output:	270 kW / 367 HP
Max. Dump Body Capacity:	19.0 m <sup>3</sup>
Payload:	30,000 kg



# LIEBHERR

# TA 230

Litronic®

Empty Vehicle Weight:	24,400 kg
Engine Output:	270 kW / 367 HP
Max. Dump Body Capacity:	19.0 m <sup>3</sup>
Payload:	30,000 kg



## Economy

Liebherr dump trucks set standards in terms of their efficiency. The Liebherr D 936 engine has been specially developed for the TA 230 Litronic and features low fuel consumption. The overall width with all versions is less than 3.00 m, ensuring that the dump truck can be transported quickly, at low cost and without bureaucracy.

## Performance

The Liebherr dump truck has been developed to ensure maximum productivity. The highest payload in its class coupled with the extraordinarily powerful engine combine to mean more material can be transported in a shorter time.

## Comfort

The Liebherr operator's cab features generous dimensions and an ergonomic design. The operator seat is individually adjustable whilst the control instruments are clearly arranged and all-round visibility is excellent. The standard air-conditioning system ensures the correct temperature in the "Liebherr feel-good cab" at all times.

## Reliability

Liebherr dump trucks are designed and built to withstand the toughest possible conditions of use. Sturdy constructions, high strength materials and our own components guarantee maximum availability and a long service life.





#### Maintenance and Service

- The bonnet and operator's cab can be tipped electrically to provide excellent service access
- Little time required for daily checks of oil and other fluids
- Time-tested Liebherr service and excellent availability of spare parts



# Economy

Liebherr dump trucks are designed for a maximum workload. The large dump body and powerful drivetrain guarantee efficient material movement. Service points with excellent access reduce servicing work and therefore downtime and running costs.

## Low operating costs

### Large dump body capacity

The dump body of the Liebherr dump truck has a capacity of 19.0 m<sup>3</sup> (with tailgate), making it the largest in this class. It can carry a payload of 30 metric tonnes.

### Powerful drivetrain

The drivetrain is designed for maximum productivity and durability. The powerful Liebherr engine and 8-speed ZF gearbox ensure fast transport times with excellent off-road features as well as high top speeds both forwards and in reverse.

### Bespoke transport

The overall width of the TA 230 Litronic is less than 3.00 m in every case which means that the dump truck can be transported at any time without a special permit. Whilst others are still organising transport, you have already arrived at your destination with Liebherr.

### Low wear

The high retarder capacity of 300 kW coupled with the wet multi-disk brakes and the powershift 6x6 drivetrain protects the components and reduces wear.

## Service support

### Ease of maintenance

Minimum time requirement for daily checks, good access and long service intervals prevent unnecessary downtimes and improve the productivity of the machine.

### Service availability

The time-tested Liebherr range of services and service personnel trained at the actual production plant ensures you get the best possible service. Our global spare parts management system guarantees fast availability.



### Productivity

- Highest payload in its class
- Payload: 30,000 kg
- Powerful engine for fast transport times and high transport capacity
- Superb fuel efficiency
- Innovative dump body heating for excellent emptying properties



### Flexibility

- Vehicle width with mounted tailgate and wide tyres less than 3.00 m
- Can be transported without requiring a special permit
- No downtime for modifications or transport organisation, saves time and money, increases capacity



#### Drivetrain

- Liebherr D 936 engine for construction machinery
- Automatic 8-speed gearbox with powershift longitudinal differential
- HD axles with self-locking differential
- Variably adjustable retarder function acts on all wheels (engine brake and gearbox retarder)
- Wet multi-disk brakes on front and middle axles require no servicing
- The third axle is braked by the cardan shaft



# Performance

The TA 230 Litronic sets standards in terms of production capacity. Thanks to its powerful engine and large dump body it can transport more material in less time. Even when it is used in heavy earthworks the TA 230 Litronic produces fast cycle times, extraordinary manoeuvrability and maximum safety.

## Well design equipment

### Engine concept

The powerful Liebherr diesel engine produces 270 kW and gives the TA 230 Litronic excellent figures on any terrain. Perfect weight distribution ensures maximum traction even on demanding inclines and in difficult ground conditions.

### Power and smoothness

Thanks to its 8-speed ZF gearbox the fully laden machine can accelerate very dynamically to a top speed of up to 57 km/h. Noisy gear shifts are a thing of the past. With four reverse gears with a top reversing speed of up to 16 km/h increases the productivity of the machine enormously.

### Braking

The variably adjustable gearbox retarder is perfectly controllable and if necessary develops a deceleration capacity which is unrivalled in this class. This means that the truck can negotiate even very steep inclines safely. The wet, oil-cooled multi-disk brakes are fitted on the front and middle axles. The third axle is braked by the cardan shaft.

## Higher handling capacity

### Hydraulic system

The load-sensing hydraulic system will tip the fully laden dump body in 12 seconds and lowers it again in just 8 seconds.

### Dump body heating system

The Liebherr dump body heating system is an innovation since it is not powered by the engine exhaust emissions but by a separate water heating system. This heats the dump body more effectively resulting in perfect dumping when the dump body is tipped.



### Handling

- Excellent acceleration and deceleration
- Good off-road features due to adequate axle compensation and ground clearance
- Excellent uphill capacity thanks to balance weight distribution
- Agility and manoeuvrability, even in reserve, four reverse gears for speeds of up to 16 km/h
- Maximum traction and safety, self-locking lateral differentials



### Dump body

- Largest basic capacity in the 30 tonne class
- Innovative dump body heating system, powerful with water circulation system
- Load sensing hydraulic system
- Low loading edge
- Excellent stability when unloading
- Dumping angle 70°



**Mobile comfort as standard**

- Steering column can be rotated and telescoped
- Operator's seat height-adjustable and adjustable to the operator's weight
- Electrically adjustable and heated exterior rear-view mirrors
- Electrically heated windscreen
- Sun blind







# Comfort

The operator's cab on the Liebherr TA 230 Litronic dump truck was developed to ensure easy operation and maximum visibility. This results in the ergonomic control concept being fully intuitive. The large windows also provide perfect visibility of the entire working area. This allows the operator to remain alert and concentrated throughout the day and ensures that he can continue to work at a high capacity all the time.

## Cab design a class above

### Deluxe cab

The modern cab provides the operator with all the comforts he needs to enable him to work productively in a pleasant atmosphere. The cab is spacious, has very good seat comfort and excellent suspension, making it ergonomic and a pleasure to work in.

### Overview

The single-piece windscreen and large side windows provide a large field of vision without any parts to get in the way. A good overview of the entire working area makes work much easier for the operator.

## Simple operation

### Control elements

All the functions are arranged logically and easy to use. The automatic gearbox, retarder and levers are precise and sensitive in use. This helps the operator retain his alertness and concentration throughout the day.

### Large display

The clear operator information system is shown on a large touchscreen display at the perfect point in front of the operator. The drive can thus identify all the machine states at a glance.

## Integral service benefits

### Making work easier

Service work can be carried out quickly since the bearings are easily accessible all over the machine.

### Simple servicing

Electrically tilting operator's cab and bonnet provide easy and safe access to all service points and make service work easier.

### Multi-function display

- Self-explanatory, high resolution control unit with touchscreen function
- Rear view monitoring with camera as standard
- Air-conditioning can be controlled using multi-function display
- Fuel consumption and machine parameters monitored
- Service hour counter



### Liebherr feel-good cab

- Cab mounted on elastic buffers for low fatigue working
- Safe overview of the entire work area through large windows
- Standard rear window protection grille and air-conditioning system
- Easy access: wide steps and ergonomic handles



#### Liebherr quality

- Sturdy steel construction made by Liebherr
- Components such as hydraulic cylinders from our in-house production facility
- Standard shut-off valve for the hydraulic system
- Solid protection for the steering cylinders as standard



# Reliability

Liebherr machines prove their work all over the world on the most diverse construction sites all over the world. Every machine features years of experience with building machinery, constant developments and the use of the very latest technologies and provide absolute reliability. Sturdy design and fitted with Liebherr components, the TA 230 Litronic is designed for a long service life.

## Quality in detail

### Liebherr components

Components such as the engine, steel components, hydraulic cylinders and electronic parts are specially developed, tested and manufacturer by Liebherr for construction machines. Components such as the engine and gearbox are tailored to each other in the design phase and provide uniform high quality.

### Reliability

Safety components installed as standard provide greater availability. The operator can concentrate fully on his work since the integral electronic system permanently compares actual to desired data. For example a standard emergency steering pump on the gearbox provides a high safety standard for both forwards and reverse manoeuvres.

## Designed for durability

### Steel construction

The rugged steel construction at the front and rear is designed to withstand the hardest conditions. We have decades of experience in producing these steel components. In addition the various parts are also improved using FEM.

### Pipework and cables

The hydraulic lines are routed to provide them with maximum protection from damage. The electric cables feature high quality materials and provide reliable supplies to all consumers.



### Time-tested technology

- Gearbox from ZF specially improved and adjusted for the Liebherr dump truck
- Axles from Kessler for rugged use by building machinery
- Also available from Liebherr rental companies



### Service-orientated

- The familiar 98% availability of spare parts around the clock
- Service personnel trained by the manufacturer ensure excellent quality service
- Dense service network provides the support you need in every single situation

# Technical Data



## Engine

Rating per ISO 9249	270 kW (367 HP) at 1,900 RPM
Max. torque	1,800 Nm at 1,500 RPM
Model	Liebherr D 936 A7/stage IIIB/Tier 4i
Type	6 cylinder in-line
Displacement	10.5 l
Engine operation	electronic direct injection turbo-charged and after-cooler reduced emissions
Harmful emissions values	in accordance with 97/68/EG stage IIIB/EPA/CARB Tier 4i
Emission control	Liebherr particle filter
Cooling system	fan variably adjustable hydrostatically driven and temperature regulated
Air filter	dry air filter with precleaner, main and safety element
Electrical system	
Operating voltage	24 V
Battery	2 x 170 Ah/12 V
Alternator	2 x 3-phase generator 28 V/80 A
Starter	7.8 kW



## Drive Train

Transmission	electronically controlled, automatic powershift transmission, torque converter with lock-up clutch, 8 gears forward, 4 gears reverse, integrated distributor gear with powershift lateral differential
Speeds	57 km/h forward 16 km/h backwards
Drive train	6 x 6 standard drive train with powershift lateral differential between front axle and rear axles



## Axles

Front axle	two swinging half axles with two hydro-pneu- matic cushioning cylinders, maintenance-free bearings, self-locking transverse differential
Rear axles	heavy duty axles with self-locking transverse differentials
Gear ratio	planetary gears in the wheel hubs



## Brakes

Retarder	retarder function consisting of engine brake and transmission retarder, variable adjust- ment, acting upon all wheels
Operating brake	2 circuit, hydraulically operated, oil cooled wet disc brake acting on front and middle axle
Parking brake	spring applied disc brake acting upon the driveshaft of rear axles (hydraulically releasable)



## Steering

Design	hydraulic, 2 dual acting cylinders, combined articulated and oscillating joint with Liebherr ball bearing ring
Steering angle	± 45°
Steering wheel turns from stop to stop	4.5



## Tires

Standard tires	23.5 R25
Design	earthmoving radial, tubeless
Option	wide base and rock tires



## Hydraulic System

Hydraulic circuit	on-demand flow control, engine driven axial piston pump, wheel driven piston pump for emergency steering
Max. flow	344 l/min.
Max. operating pressure	250 bar
Operation	
Dumping	dump body operating lever with automatic engine rpm increase
Retarder	variably adjustable hand lever, retarder adjustment preselectable, gas pedal overrides retarder
Transmission	automatic mode, gear preselection, manual shift possible
Filtration	return filter, 12 µm



## Operator's Cab

Cab	elastic suspension, closed pressure ventila- tion, electro-hydraulically tiltable by 45° to the right, integrated ROPS/FOPS structure, tinted safety glass, wiper/washing system with inter- val operation for front window, sound isolated, telescopic and horizontally adjustable steering column, sliding window left and right, fresh air filter with prefilter, additional recirculated air filter, exterior mirror and front window heater
Operator's seat Comfort	air cushioned operator's seat with headrest, lap belt, automatic weight adjustment, length- wise and crosswise horizontal suspension, adjustable seat cushion inclination and length and mechanical lumbar vertebrae support
Operator's seat Premium (Option)	in addition to operator's seat comfort: seat heater, passive seat climatization, pneumatic lumbar vertebrae support
Ventilation	heater and air conditioning, pressure ventila- tion with fresh air intake and filtration, variable fan
Heating	warm water heater, defrost function for front and side windows



## Filling Quantities

Fuel tank	370 l
Cooling system	120 l
Engine oil (incl. filter)	34 l
Hydraulic tank	250 l
Cooling oil tank brake	64 l
Transmission	60 l
Wheel hub each	3.3 l
Axles	33 l
Differential	18 l



## Dump Body Capacity

Volume	
swept	14.2 m <sup>3</sup>
stacked 2:1	18.0 m <sup>3</sup> according to ISO 6483
with flap swept	14.8 m <sup>3</sup>
with flap stacked 2:1	19.0 m <sup>3</sup> according to ISO 6483
Payload	30,000 kg
Dumping time	12 s
Lowering time	8 s
Dump angle	70°

# Dimensions

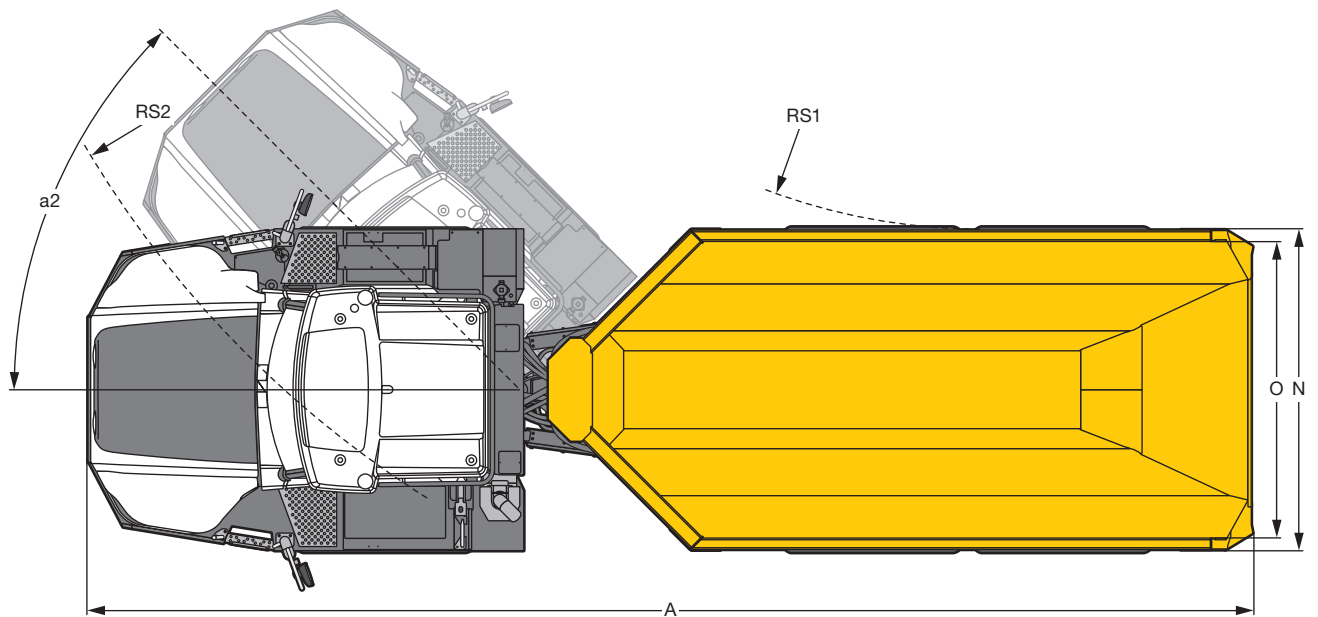
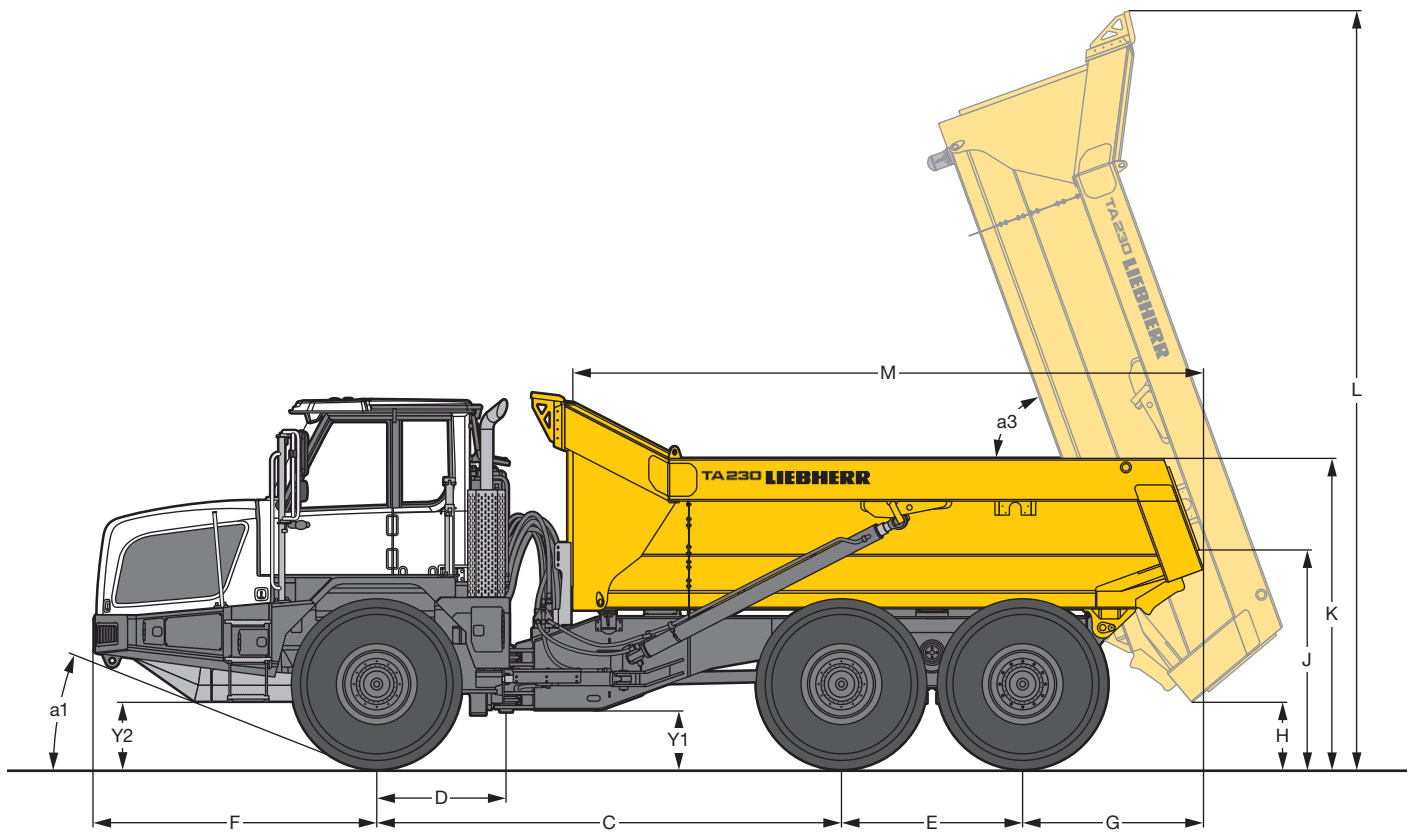

	mm
A	10,372
C	4,350
D	1,210
E	1,700
F	2,650
G	1,672
H	570
J	1,980
K	2,836
L	6,775
M	5,888

	mm
N	2,845
O	2,645
RS1	4,260
RS2	8,385
Y1	465
Y2	615
a1	22°
a2	45°
a3	70°

# Dimensions

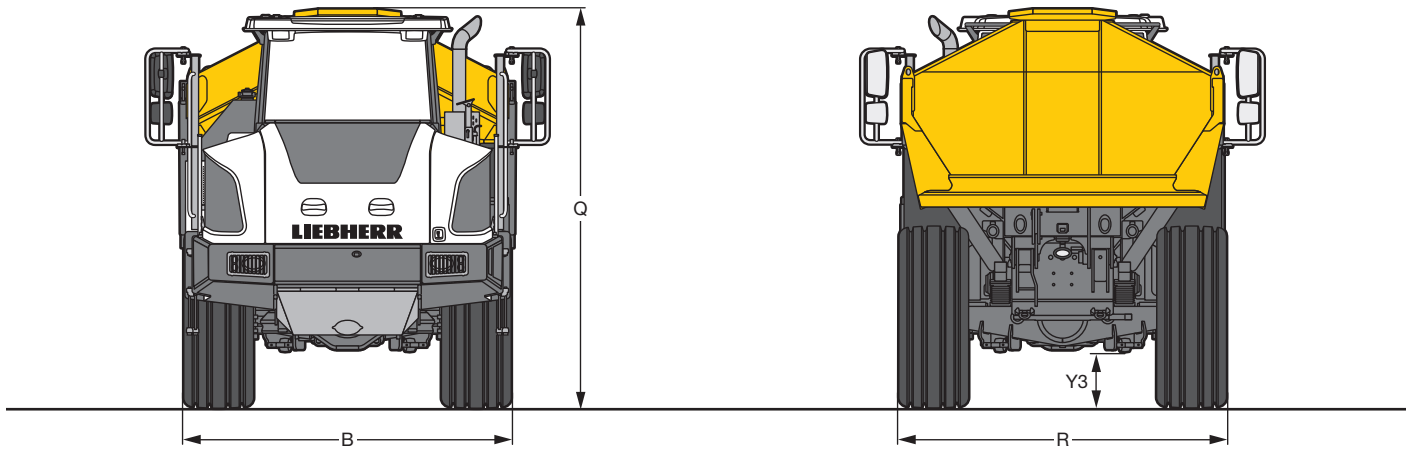

## Transport Dimensions Incl. option for dump body flap and including wide base tires

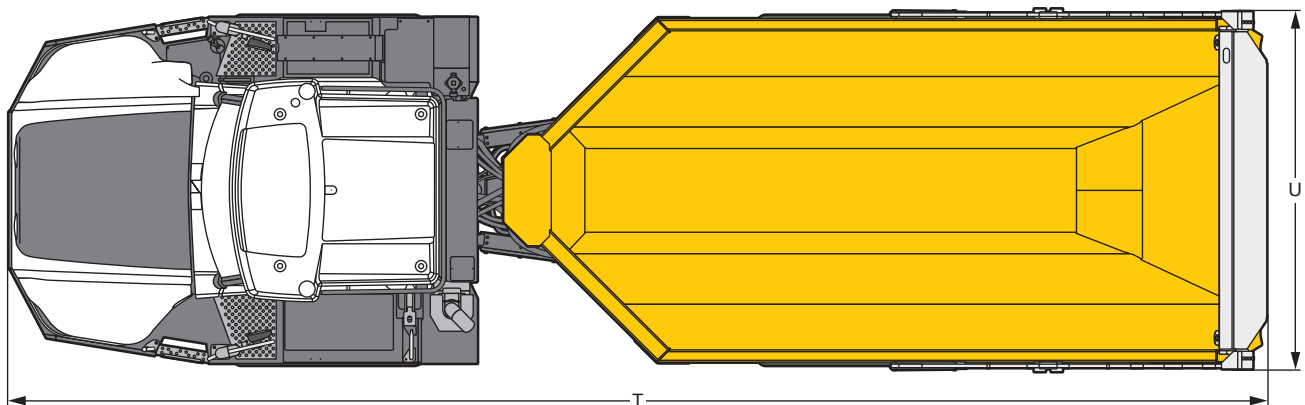
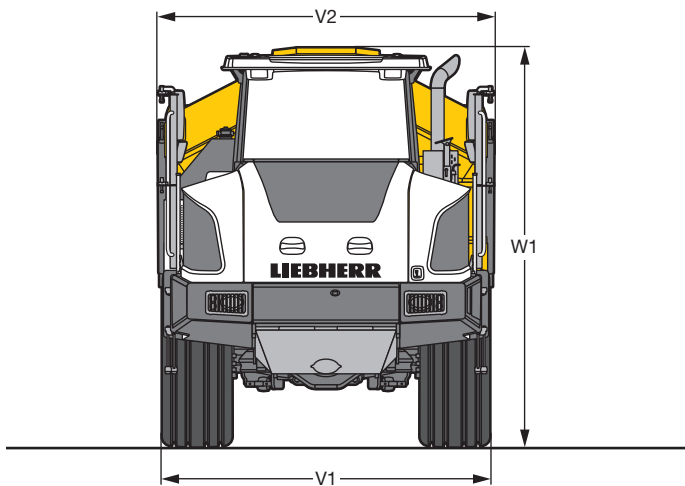

	mm
B	2,885
Q	3,395
R	2,885
T	10,325
U	2,960

	mm
V1	2,960
V2	2,980
W1	3,395
Y3	410

# Equipment



## Vehicle

Dual-circuit braking system	•
Steps on front carriage	•
Tires 23.5 R25	•
Tires wide base 750/65 R25	+
Tires rock 23.5 R25	+
Fire protection system	+
Cabine tiltable electro-hydraulically to the right	•
Low temperature equipment (-25 °C)	+
Low temperature equipment (-40 °C)	+
Articulating lock	•
Wet disk brakes	•
Liebherr hydraulic oil from -20 °C to +40 °C	•
Liebherr hydraulic oil, specially for warm or cold regions	+
Liebherr particle filter	•
Engine hood opening electro-hydraulically	•
Dump body heating	+
Dump body flap	+
Dump body safety support	•
Transverse differentials self-locking	•
Retarder function highly effective, consisting of a combination of engine brake and transmission retarder	•
Retarder function variably adjustable, overridable by the gas pedal	•
Back-up alarm acoustic	•
Rear-view mirrors electrically adjustable and heatable	•
Rear-view mirror standard and wide angle	•
Special coating	+
Standard 6 x 6 drive train with powershiftable lateral differential between front axle and rear axle	•
Overflow protection (screw-on)	+
Wear protection for dump body	+
Electronic immobilizer	•
Weighing device	+
Automatically central lubrication system	+



## Operator's Cab

Storage compartment	•
Analog instruments for speed, rpm, fuel tank, coolant temperature at multifunctional display	•
Cab lights rear, halogen	+
Cab lights front, halogen	•
Ventilation system pressure cabine for special applications	+
On-board computer with multifunctional display	•
Operator's seat Comfort	•
Operator's seat Premium	+
Fire extinguisher	+
FOPS cab protection	•
Bottle holder small and large	•
Rubber floor mat, removable	•
Dome light	•
Coat hook	•
Air conditioner	•
Electric cooler	+
LiDAT Plus (extended Liebherr data transfer system)*	•
Radio Comfort	+
Preparation for radio installation	•
ROPS cab protection	•
Rear view monitoring with camera**	•
Double warning beacon on cab	+
Window heater front window	•
Sliding window front left and right	•
Front guard rear window	•
Sun blind	•
Auxiliary heating, adjustable (week time switch)	+
Additional power socket 12 V	•
Additional power socket 24 V	•
Trainer seat with automatic seat belt	•
Cigarette lighter and ashtray	•

• = Standard, + = Option

\* = optionally extendable after one year

**Options and/or special attachments, supplied by vendors other than Liebherr, are only to be installed with the knowledge and approval of Liebherr in order to retain warranty.**

# The Liebherr Group of Companies



## Wide Product Range

The Liebherr Group is one of the largest construction equipment manufacturers in the world. Liebherr's high-value products and services enjoy a high reputation in many other fields. The wide range includes domestic appliances, aerospace and transportation systems, machine tools and maritime cranes.

## Exceptional Customer Benefit

Every product line provides a complete range of models in many different versions. With both their technical excellence and acknowledged quality, Liebherr products offer a maximum of customer benefits in practical application.

## State-of-the-art Technology

To provide consistent, top quality products, Liebherr attaches great importance to each product area, its components and core technologies. Important modules and components are developed and manufactured in-house, for instance the entire drive and control technology for construction equipment.

## Worldwide and Independent

Hans Liebherr founded the Liebherr family company in 1949. Since that time, the enterprise has steadily grown to a group of more than 130 companies with over 38,000 employees located on all continents. The corporate headquarters of the Group is Liebherr-International AG in Bulle, Switzerland. The Liebherr family is the sole owner of the company.

[www.liebherr.com](http://www.liebherr.com)

## Liebherr-Hydraulikbagger GmbH

Liebherrstraße 12, D-88457 Kirchdorf/Iller

☎ +49 7354 80-0, Fax +49 7354 80-72 94

[www.liebherr.com](http://www.liebherr.com), E-Mail: [info.lhb@liebherr.com](mailto:info.lhb@liebherr.com)

[www.facebook.com/LiebherrConstruction](https://www.facebook.com/LiebherrConstruction)