

DRUM WIDTH: 2100mm (82.7in) OPERATING WEIGHT: 14500kg (31967lb) / 14900kg (32849lb)

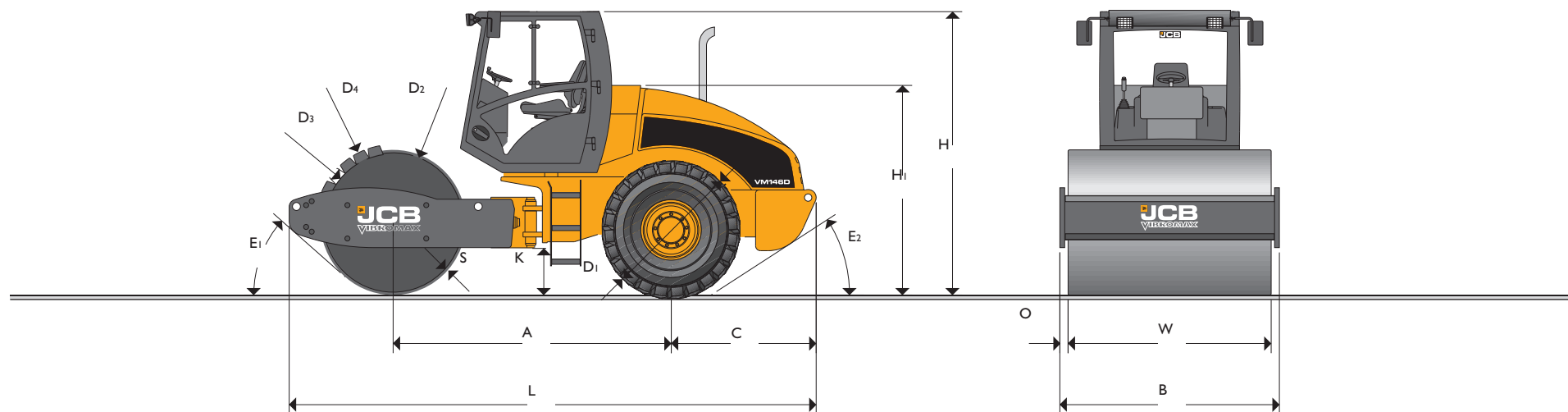

STATIC DIMENSIONS

Dimensions in millimetres (in)		
A	Wheelbase	2996 (118.0)
B	Overall width	2270 (89.4)
C	Axle to rear face	1651 (65.0)
D1	Wheel diameter	1520 (59.8)
D2	Drum diameter (smooth drum)	1500 (59.1)
D3	Inner diameter padfoot drum	1400 (55.1)
D4	Outer diameter padfoot drum	1600 (63.0)
H	Total travel clearance	2935 (115.6)
H1	Height to top of seat	2160 (85.0)
K	Ground clearance	447 (17.6)
L	Total travel length	5722 (225.3)
O	Overhang	85 (3.3)
S	Drum thickness	35 (1.4)
W	Drum width	2100 (82.7)
E1	Front departure angle	41°
E2	Rear departure angle	29°

OPERATING DATA

		VMI46D		VM146PD	
		1	2	1	2
Operating weight	kg (lb)	14500 (31967)		14900 (32849)	
Operating axle load front / rear	kg (lb)	8000 (17637) / 6500 (14330)		8400 (18519) / 6500 (14330)	
Operating linear load front	kg/cm (lb/in)	38.1 (213)			
Vibration stage					
Exciter frequency	Hz (vpm)	29 (1740)	35 (2100)	29 (1740)	35 (2100)
Nominal amplitude	mm (in)	1.8 (0.071)	0.8 (0.031)	1.8 (0.071)	0.8 (0.031)
Centrifugal force	kN (lbf)	297 (66768)	192 (43163)	317 (71264)	205 (46086)
Centrifugal force / drum width	N/cm (lbf/in)	1414 (808)	914 (522)	1510 (862)	976 (557)
Compaction depth up to	cm (in)	120 (47)	100 (39)	130 (51)	110 (43)
Working speed (forward/reverse) max.	km/h (mph)	7.3 (4.5)		7.3 (4.5)	
Travel speed (forward/reverse) max.	km/h (mph)	11.4 (7.1)		11.4 (7.1)	
Steering lock angle	degrees	±35		±35	
Vertical oscillation	degrees	±15		±15	
Inner turning radius	m (in)	3.6 (142)		3.6 (142)	
Tyres		23.1 - 26 / 8 PRAWT		23.1 - 26 / 8 PR Dyna Torque II	
Number of padfeet				132	
Height of padfoot	mm (in)			100 (3.9)	
Gradeability up to	degrees (%)	32 (62)		33 (65)	

ENGINE

Four and six-cylinder, water-cooled, four-stroke, turbo-charged diesel engine with charge air cooler.

		Tier 2	Tier 3
Make		Cummins	JCB
Model		B 5.9 - 150C	444TCA
Piston displacement	cm ³ (in ³)	5880 (359)	4399 (268)
Performance – DIN 6271	kW (hp)	129 (173)	120 (161)
Operating speed	min ⁻¹ (rpm)	2200 (2200)	2200 (2200)
Starting device		Electric motor	Electric motor
Air cleaner		Dry cartridge + safety cartridge	Dry cartridge + safety cartridge
Fuel filter		Cartridge	Cartridge

PROPULSION

Infinitely variable hydrostatic direct drive by variable displacement motor on rear axle and drum, Multidisc self-locking differential (NoSPIN).

EXCITER DRIVE

Electrically controlled hydrostatic direct drive on drum.

EXCITER

Single-shaft circular exciter with overturning weights.

STEERING SYSTEM

Servo assisted center articulation with vertical oscillation.

SERVICE CAPACITIES

Fuel	litres (US gal)	400 (105.7)
Engine oil (engine)	litres (US gal)	14.5 (3.8)
Gear oil (exciter)	litres (US gal)	12 (3.2)
Hydraulic oil	litres (US gal)	80 (21.1)
Coolant	litres (US gal)	19 (5.0)

BRAKING SYSTEM

Service brake: Hydrostatic propulsion system.
Parking brake: Hydraulically released multi-disk brake on rear axle and drum drive.
Emergency brake: Electrically controlled, disk brake on rear axle and drum drive.

ELECTRICAL SYSTEM

Voltage	V	12
Battery capacity	Ah	143
Alternator	A	max. 95

INDICATORS AND SWITCHES

Hour meter, fuel, engine temperature, engine oil pressure, battery charging current, hydraulic oil and air filter condition, parking brake, neutral position control lever, speed range selection, frequency, AVC (automatic vibration control, acoustic back-up alarm).
 Optional lighting, turn signal, hazard-warning lights.

