

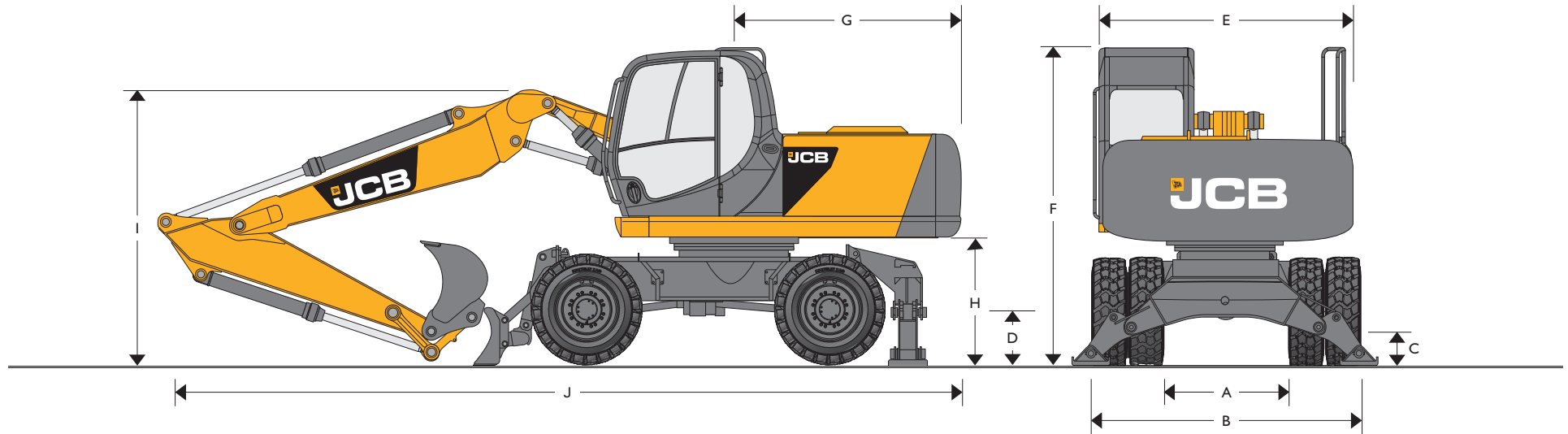

MAX. OPERATING WEIGHT: 15522 kg (34220 lb) ENGINE POWER: 97 kW (130 hp)



STATIC DIMENSIONS

Dimensions in millimetres (ft-in)	
A	Internal width between dual wheels 1330 (4-4)
B	External width over dual wheels 2490 (8-2)
C	Ground clearance 350 (1-2)
D	Height to axle centre line dual wheels 498 (1-7)
	Height to axle centre line single wheels 519 (1-8)
E	Overall width (handrail removed) 2480 (8-2)
F	Height over cab 3155 (10-4)
G	Tail length 2135 (7-0)
H	Clearance under counterweight 1240 (4-1)

Monoboam 4.7m (15ft 4in)

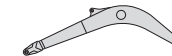

Dipper length		2.10m (6ft 11in)	2.50m (8ft 2in)	3.0m (9ft 10in)
I	Transport boom height mm (ft-in)	3040 (10-0)	3040 (10-0)	3040 (10-0)
J	Transport length mm (ft-in)	7665 (24-10)	7685 (25-2)	7715 (25-4)

Triple articulated boom 5.0m (16ft 4in)



Dipper length		2.10m (6ft 11in)	2.50m (8ft 2in)	3.0m (9ft 10in)
I	Transport boom height mm (ft-in)	3040 (10-0)	3040 (10-0)	3040 (10-0)
J	Transport length mm (ft-in)	7395 (24-3)	7735 (25-4)	7975 (26-2)

CHASSIS OPTIONS

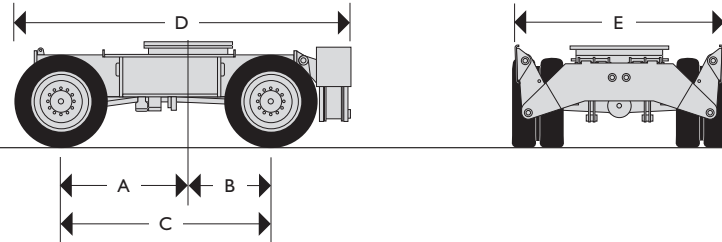

Dimensions in millimetres (ft-in)

A	Centre of slew ring to front axle	1500 (4-11)
B	Centre of slew ring to rear axle	1000 (3-3)
C	Wheelbase	2500 (8-2)
D	Length including rear stabilizers	3950 (12-11)
E	Width over stabilizers (raised)	2480 (8-1)

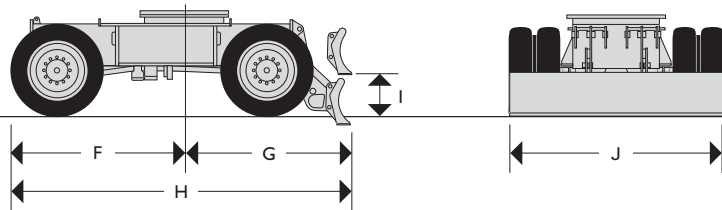

Dimensions in millimetres (ft-in)

F	Centre of slew ring to face of front tyre	1990 (6-6)
G	Centre of slew ring to rear dozer blade (lowered)	2090 (6-10)
H	Length including rear dozer blade (raised)	4050 (13-3)
I	Ground level to bottom of rear dozer blade (raised)	450 (1-6)
J	Dozer blade width	2480 (8-1)

CHASSIS OPTIONS

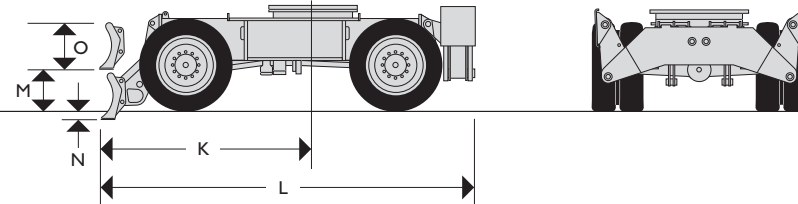

Dimensions in millimetres (ft-in)

K	Centre of slew ring to front dozer blade (lowered)	2530 (8-3)
L	Length including stabilizers and dozer blade (raised)	4460 (14-7)
M	Ground level to bottom of front dozer blade (raised)	450 (1-6)
N	Dozer blade dig depth	130 (0-5)
O	Dozer blade height	500 (1-8)

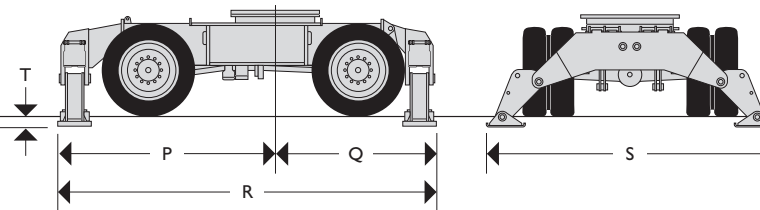

Dimensions in millimetres (ft-in)

P	Centre of slew ring to front stabilizers	2520 (8-3)
Q	Centre of slew ring to rear stabilizers	1960 (6-5)
R	Length including front and rear stabilizers	4480 (14-8)
S	Width over stabilizers (lowered)	3550 (11-8)
T	Stabilizer lift height	130 (0-5)



ENGINE

Model	JCB Dieslemax 444 TCA-97 Eu Stage IIIA, EPA Tier 3 compliant.
Type	Water cooled, 4-stroke, 4-cylinder in-line, direct injection, turbocharged diesel.
Rated power (ISO14899 (SAE J1995))	97kW (130hp) at 2200rpm.
Piston Displacement	4.399 litres (1.16 UK gal).
Injection	Electronic injection.
Air Filtration	Dry element with secondary safety element and in cab warning indicator.
Cooling	Large capacity radiator.
Starting system	24 volt – 4kW.
Batteries	2 x 12 volt Heavy Duty.
Alternator	24 volt 55 amp.
Refuelling pump	Electric type.

SWING SYSTEM

Drive train	Axial piston motor and planetary reduction final drive.
Swing brake	Hydraulic braking plus automatic spring applied disc type parking brake.
Swing speed	13.4RPM
Swing gear	Large diameter, internally toothed fully sealed grease bath lubricated.

CHASSIS

Structure	High strength flanged 'u' section.
Chassis Options:	
Dozer Blade	Front or rear pin mount.
Stabilisers	Front or rear pin mount, independently operable – plus combinations.
Grab Stowage	Heavy duty, pin mounted stowage bar.
Transmission	Hydrostatic drive via piston motor and powershift transmission.
Travel speed	Creep speed 3.3kph Low ratio 14kph High ratio 35kph (22mph)
Drawbar pull	86.6 kN
Axles	Four wheel drive. Front steering axle oscillates for rough ground mobility.
Axle load capacity	26 tonnes
Axle oscillation	+/- 8.5 degrees
Ground clearance	350mm
Steering	Fully hydraulic system.
Turning radius	
To outside of tyres	5.45m (17ft 10in)
To outer edge of front mounted dozer blade	6.06m (19ft 10in)
Brakes	All hydraulic, dual circuit brake system.
Parking Brake	Built into the transmission.
Gradability	35° 70% max. continuous.

EXCAVATOR END

Monoboom available along with a choice of dipper lengths to suit the requirements of reach, dig-depth, loadover height, tearouts and site versatility. Reserve strength is built into the fully welded structures for hydraulic hammer and other arduous operations. Fabricated bucket tipping links are provided with a choice of lift points. Strong, durable construction, large cross sections and multi plate fabrications to withstand high stress applications. The 4.70m (15ft 4in) boom is designed to ensure the optimum digging envelope when matched with the three dipper lengths. Low maintenance bronze alloy bushes with graphite plugs are fitted to boom base and boom to dipper pivots resulting in 1000 hour greasing intervals at these points.

EXCAVATOR END – T.A.B.

Triple articulated boom available along with a choice of dipper lengths to suit the requirements of reach, dig-depth, loadover height, tearouts and site versatility. Reserve strength is built into the fully welded structures for hydraulic hammer and other arduous operations. Fabricated bucket tipping links are provided with a choice of lift points. Strong, durable construction, large cross sections and multi plate fabrications to withstand high stress applications. The boom is designed to ensure the optimum digging envelope when matched with the three dipper lengths.



MAIN HYDRAULIC SYSTEM

System	Load-sensed hydraulic system with twin variable flow piston pumps providing flow-on-demand for maximum efficiency.
Main pumps	2 variable displacement axial piston type
Maximum flow	2 x 137 l/min (30 UK gpm)
Main circuit pressure	314 bar (4555 lb/in ²)
With power boost	343 bar (4975 lb/in ²)
Servo pump	Gear type
Maximum flow	19 l/min (5 UK gpm)
Servo pressure	40 bar (580 lb/in ²)
Optional Circuits:	
Hammer	Includes automatic engine speed setting and return filter.
Maximum flow	100 l/min (22 UK gpm)
Maximum pressure	314 bar (4555/4975 lb/in ²) (pre-set to 180 bar (2610 lb/in ²))
Grab operation	
Maximum flow	137 l/min (30 UK gpm)
Maximum pressure for grab ram operation	314 (343) bar (4555/4975 lb/in ²)
Low Flow Pipework	Gear pump max flow 34L/min (7 UK gpm)
Hydraulic Cylinders	Hardened, chromed piston rods and end cushioning on boom, dipper and bucket crowd cylinder.
Filtration	
In tank	150 micron, suction strainer.
Main return line	10 micron, fibreform element.
Pilot line	10 micron, paper element.
Plexus by pass line	1.5 micron paper element.
Hydraulic hammer return	10 micron, reinforced microform element.
Cooling	
Worldwide cooling is provided by a single faced engine water, hydraulic oil and intercooler with swing forwards air conditioning condenser for easy cleaning.	

TYRES

Twins	10.00 x 20 tyres (16PR) with spacer ring.
Single	18R x 19.5 tyres (Radials).

CAB

Excellent digging, loading and positioning visibility results from the careful design of front, side and roof lights. All screens are tinted to improve in cab conditions.

Fully opening front screen is very smooth to operate and as the lower screen is stored within the top screen frame it makes complete front screen opening easy, fast and convenient.

Fresh air ventilation available from opening door window, opening slot in front screen and fully opening front screen.

Parallelogram wash wiper for upper screen ensuring good wiped area for maximum visibility. Wiper motor is fitted in the left hand side of the roof screen so as not to affect bucket visibility when loading. Optional lower screen wiper available.

Fresh air ventilation and heater with windscreen demister. Infinitely variable blower speed, temperature and recirculation control.

Climate control. Fully adjustable deluxe suspension seat with arm rest adjustment and backrest recline. Optional radio with digital tuner fitted into the roof lining for maximum protection. Conveniently placed radio mute button incorporated into lower console.

12v power point and mobile phone holder built into the right hand console. Courtesy light can be operated from ground level and is illuminated for five minutes or until switched off improving operator access at night. Cab mounted roller blind protects operator from suns' glare through front or top screens.

**AMS – ADVANCED MANAGEMENT SYSTEM**

Four selectable working modes link the operators control movements with the engine and hydraulic systems to maximise productivity and efficiency.

- A (Auto)** Up to 100% engine power and 100% flow. Gives variable power and speed depending on the operator's input, matching the demand for output and efficiency to the job. Power boost is automatically activated in this mode should hard conditions be encountered. Auto idle cuts in after a period of inactivity (between 5 and 30 seconds as set by the operator)
- E (Economy)** 80% engine power. 95% of hydraulic flow maximises economy while maintaining excellent output.
- P (Precision)** 55% engine power. 90% of hydraulic flow for fine control of grading operations.
- L (Lifting)** 55% engine power. 63% of hydraulic flow with permanent power boost for maximum lifting power and control.

The Auto mode allows the AMS processor to select the optimum operational performance to match the demands of the job while the three alternative modes give precise matching of application when specific tasks are undertaken.

The adjustable position monitor mounted on the front right hand pillar of the cab gives the operator a constant read out of mode, tracking range, operating temperature and a host of other information, while retaining excellent visibility of the monitor and the job being carried out.

The required flow for hammer applications can be set and stored in the AMS memory and is automatically activated whenever the hammer pedal is depressed.

A maintenance indicator warns of imminent service needs, and all servicing and basic checks can be carried out using only the in cab display.

STANDARD EXCAVATING BUCKETS

All buckets are JCB – Esco fully welded steel, with sealed, hardened steel pivot pins and replaceable wear parts.

Max Width mm (in.)	Capacity (SAE heaped) cu.m (cu.yd)	Weight kg (lb)
600 (24)	0.32 (0.42)	369 (814)
750 (30)	0.43 (0.56)	423 (933)
900 (36)	0.55 (0.72)	468 (1032)
1000 (40)	0.63 (0.82)	507 (1118)
1100 (44)	0.72 (0.94)	537 (1184)
1200 (48)	0.80 (1.05)	576 (1270)

SERVICE CAPACITIES

	litres	UK gal
Fuel tank	253	56
Engine coolant	19.7	4.3
Engine oil	20.4	4.5
Swing reduction gear	2.2	0.5
Hydraulic system	124	27.3
Hydraulic tank	73	16.0
Transmission	2.5	0.55
Axle differentials (each)	Rear 12, Front 14	Rear 2.6, Front 3
Axle hubs (each)	2.0	0.5



STANDARD EQUIPMENT

Engine fan guard; Cold start pre-heat; Auto engine warm up; Double element air cleaner; Heavy duty alternator; Electrics isolator; Heavy duty batteries; Cab & engine soundproofing; Cab heater & screen demister; Tinted glass; Interior light; Coat hook; Ashtray; Operator's storage box; Removable floor mat; Windscreen wash/wipe; Plug-in power socket; Automatic power boost; Auto-idle; One-touch engine speed control; Hydraulic cushion control; Plexus hydraulic oil filtration; HSP pressure test points; Auxiliary pipework mounting brackets; Work lights – boom & mainframe mounted; Upper structure under covers; Swing system cover; External mirrors; Handrail & non slip walk ways;

OPTIONAL EQUIPMENT

Hose burst check valves & overload warning system; Tipping link mounted lift points; General purpose buckets; Ditch/grading buckets; Quickhitch buckets; Hydraulic hammers; Auxiliary pipework (full and low flow); Air conditioning or climate control; Cab mounted & rear work lights; Rotating beacon; Rain guard; Biodegradeable oil; Air suspension seat with heated pad and lumbar support adjustment; Electric refuelling pump; Lower screen wiper; Radio cassette player; Cruise control. FOPS (Level 2) operator protection; ROPS cab; immobiliser; LiveLink; HRC; Proportional control; Widecore cooling pack; Rear view camera; 2F axles hub brakes; 2F axles wide hub brakes.

OPERATING WEIGHTS

Chassis					
	13262kg (29238lb)	13702kg (30208lb)	14142kg (31178lb)	14682kg (32368lb)	15022kg (33118lb)
	13762kg (30340lb)	14202kg (31310lb)	14642kg (32280lb)	15182kg (33471lb)	15522kg (34220lb)

Machine equipped with excavating bucket and dual wheels. For single wheels subtract 400kg (880lb).

LIFT CAPACITIES – Dipper Length: 2.10m, 4.70m Monoboom, Rear dozer, No bucket.
JS145W MONO

Reach	3m (9ft 10in)		4m (13ft 1in)		5m (16ft 5in)		6m (19ft 8in)		Capacity at Max Reach		
											mm
Load Point Ht.	kg	kg	kg	kg	kg	kg	kg	kg	kg	kg	mm
6.0m (19ft 8in)			3240*	3240*	3350*	3350*			2810*	2810*	5368
5.0m (16ft 5in)	3810*	3810*	3540*	3540*	3400*	3400*	2750*	2600	2660*	2590	6011
4.0m (13ft 1in)	5090*	5090*	4150*	4150*	3690*	3410	3480*	2580	2620*	2310	6434
3.0m (9ft 10in)	6840*	6840*	4950*	4550	4110*	3300	3670*	2530	2650*	2150	6679
2.0m (6ft 7in)			5710*	4360	4540*	3200	3900*	2480	2740*	2080	6767
1.0m (3ft 3in)	4750*	4750*	6220*	4230	4880*	3110	4090*	2430	2920*	2080	6704
0m	7050*	6410	6420*	4160	5050*	3060	4170*	2400	3200*	2170	6485
- 1.0m (- 4ft 11in)	8310*	6430	6330*	4150	5010*	3050	4020*	2400	3680*	2360	6093
- 2.0m (- 6ft 7in)	7630*	6490	5900*	4180	4630	3070			4010*	2730	5490
- 3.0m (- 9ft 10in)	6420*	6420*	4920*	4270					4010*	3550	4592

LIFT CAPACITIES – Dipper Length: 2.10m, 4.70m Monoboom, Rear stabilisers, No bucket.
JS145W MONO

Reach	3m (9ft 10in)		4m (13ft 1in)		5m (16ft 5in)		6m (19ft 8in)		Capacity at Max Reach		
											mm
Load Point Ht.	kg	kg	kg	kg	kg	kg	kg	kg	kg	kg	mm
6.0m (19ft 8in)			3240*	3240*	3350*	3350*			2810*	2810*	5368
5.0m (16ft 5in)	3810*	3810*	3540*	3540*	3400*	3400*	2750*	2750*	2660*	*2660	6011
4.0m (13ft 1in)	5090*	5090*	4150*	4150*	3690*	3690*	3480*	2920	2620*	2610	6434
3.0m (9ft 10in)	6840*	6840*	4950*	4950*	4110*	3750	3670*	2870	2650*	2440	6679
2.0m (6ft 7in)			5710*	5020	4540*	3640	3900*	2810	2740*	2360	6767
1.0m (3ft 3in)	4750*	4750*	6220*	4880	4880*	3560	4090*	2760	2920*	2370	6704
0m	7050*	7050*	6420*	4810	5050*	3500	4170*	2730	3200*	2460	6485
- 1.0m (- 4ft 11in)	8310*	7600	6330*	4800	5010*	3490	4020*	2730	3680*	2680	6093
- 2.0m (- 6ft 7in)	7630*	7630*	5900*	4830	4630*	3520			4010*	3110	5490
- 3.0m (- 9ft 10in)	6420*	6420*	4920*	4920*					4010*	4010*	4592

LIFT CAPACITIES – Dipper Length: 2.10m, 4.70m Monoboom, Front dozer, Rear stabilisers, No bucket.
JS145W MONO

Reach	3m (9ft 10in)		4m (13ft 1in)		5m (16ft 5in)		6m (19ft 8in)		Capacity at Max Reach		
											mm
Load Point Ht.	kg	kg	kg	kg	kg	kg	kg	kg	kg	kg	mm
6.0m (19ft 8in)			3240*	3240*	3350*	3350*			2810*	2810*	5368
5.0m (16ft 5in)	3810*	3810*	3540*	3540*	3400*	3400*	2750*	2750*	2660*	2660*	6011
4.0m (13ft 1in)	5090*	5090*	4150*	4150*	3690*	3690*	3480*	3480*	2620*	2620*	6434
3.0m (9ft 10in)	6840*	6840*	4950*	4950*	4110*	4110*	3670*	3630	2650*	2650*	6679
2.0m (6ft 7in)			5710*	5710*	4540*	4540*	3900*	3570	2740*	2740*	6767
1.0m (3ft 3in)	4750*	4750*	6220*	6220*	4880*	4560	4090*	3510	2920*	2920*	6704
0m	7050*	7050*	6420*	6310	5050*	4510	4170*	3480	3200*	3130	6485
- 1.0m (- 4ft 11in)	8310*	8310*	6330*	6290	5010*	4490	4020*	3480	3680*	3420	6093
- 2.0m (- 6ft 7in)	7630*	7630*	5900*	5900*	4630*	4520			4010*	3980	5490
- 3.0m (- 9ft 10in)	6420*	6420*	4920*	4920*					4010*	4010*	4592



Lift capacity front and rear.



Lift capacity full circle.

Notes:

- For lifting capacity including bucket, subtract total weight of bucket or bucket and quickhitch from above values.
- Lifting capacities are based on ISO 10567, that is: 75% of minimum tipping load or 87% of hydraulic lift capacity, whichever is the less. Lifting capacities marked* are based on hydraulic capacity.
- Lift capacities assume that the machine is on firm, level ground.
- Lift capacities may be limited by local regulations. Please refer to your dealer.

LIFT CAPACITIES – Dipper Length: 2.10m, 4.70m Monoboom, Front stabiliser, Rear stabiliser, No bucket.
JS145W MONO

Reach	3m (9ft 10in)		4m (13ft 1in)		5m (16ft 5in)		6m (19ft 8in)		Capacity at Max Reach		
											mm
Load Point Ht.	kg	kg	kg	kg	kg	kg	kg	kg	kg	kg	mm
6.0m (19ft 8in)			3240*	3240*	3350*	3350*			2810*	2810*	5368
5.0m (16ft 5in)	3810*	3810*	3540*	3540*	3400*	3400*	2750*	2750*	2660*	2660*	6011
4.0m (13ft 1in)	5090*	5090*	4150*	4150*	3690*	3690*	3480*	3480*	2620*	2620*	6434
3.0m (9ft 10in)	6840*	6840*	4950*	4950*	4110*	4110*	3670*	3670*	2650*	2650*	6679
2.0m (6ft 7in)			5710*	5710*	4540*	4540*	3900*	3900*	2740*	2740*	6767
1.0m (3ft 3in)	4750*	4750*	6220*	6220*	4880*	4880*	4090*	3880*	2920*	2920*	6704
0m	7050*	7050*	6420*	6420*	5050*	5010*	4170*	3840*	3200*	3200*	6485
- 1.0m (- 4ft 11in)	8310*	8310*	6330*	6330*	5010*	4990*	4020*	3850*	3680*	3680*	6093
- 2.0m (- 6ft 7in)	7630*	7630*	5900*	5900*	4630*	4630*			4010*	4010*	5490
- 3.0m (- 9ft 10in)	6420*	6420*	4920*	4920*					4010*	4010*	4592

LIFT CAPACITIES – Dipper Length: 2.50m, 4.70m Monoboom, Rear dozer, No bucket.
JS145W MONO

Reach	3m (9ft 10in)		4m (13ft 1in)		5m (16ft 5in)		6m (19ft 8in)		Capacity at Max Reach		
											mm
Load Point Ht.	kg	kg	kg	kg	kg	kg	kg	kg	kg	kg	mm
6.0m (19ft 8in)			2850*	2850*	2990*	2990*			2990*	2990*	5828
5.0m (16ft 5in)			3160*	3160*	3110*	3110*	3130*	2770*	2190*	2190*	6424
4.0m (13ft 1in)	4420*	4420*	3780*	3780*	3440*	3440*	3260*	2730*	2160*	2160*	6821
3.0m (9ft 10in)	6110*	6110*	4600*	4600*	3880*	3490*	3490*	2680*	2180*	2090*	7053
2.0m (6ft 7in)	7700*	7040*	5430*	4620*	4360*	3370*	3760*	2610*	2260*	2030*	7136
1.0m (3ft 3in)	6200*	6200*	6050*	4460*	4750*	3280*	4000*	2550*	2400*	2030*	7076
0m	7380*	6710*	6380*	4370*	5010*	3210*	4150*	2510*	2620*	2100*	6869
- 1.0m (- 4ft 11in)	8560*	6700*	6410*	4340*	5060*	3180*	4130*	2500*	2970*	2260*	6501
- 2.0m (- 6ft 7in)	8030*	6740*	6130*	4350*	4840*	3190*			3590*	2560*	5940
- 3.0m (- 9ft 10in)	7060*	6840*	5420*	4410*	4090*	3260*			3900*	3160*	5124

LIFT CAPACITIES – Dipper Length: 2.50m, 4.70m Monoboom, Rear stabilisers, No bucket.
JS145W MONO

Reach	3m (9ft 10in)		4m (13ft 1in)		5m (16ft 5in)		6m (19ft 8in)		Capacity at Max Reach		
											mm
Load Point Ht.	kg	kg	kg	kg	kg	kg	kg	kg	kg	kg	mm
6.0m (19ft 8in)			2850*	2850*	2990*	2990*			2290*	2290*	5828
5.0m (16ft 5in)			3160*	3160*	3110*	3110*	3130*	3000*	2190*	2190*	6424
4.0m (13ft 1in)	4420*	4420*	3780*	3780*	3440*	3440*	3260*	2960*	2160*	2160*	6821
3.0m (9ft 10in)	6110*	6110*	4600*	4600*	3880*	3800*	3490*	2900*	2180*	2180*	7053
2.0m (6ft 7in)	7700*	7040*	5430*	5100*	4360*	3680*	3760*	2840*	2260*	2200*	7136
1.0m (3ft 3in)	6200*	6200*	6050*	4930*	4750*	3590*	4000*	2780*	2400*	2200*	7076
0m	7380*	7380*	6380*	4840*	5010*	3520*	4150*	2740*	2620*	2280*	6869
- 1.0m (- 4ft 11in)	8560*	7590*	6410*	4800*	5060*	3490*	4130*	2720*	2970*	2450*	6501
- 2.0m (- 6ft 7in)	8030*	7640*	6130*	4820*	4840*	3500*			3590*	2780*	5940
- 3.0m (- 9ft 10in)	7060*	7060*	5420*	4880*	4090*	3560*			3900*	3450*	5124



Lift capacity front and rear.













Lift capacity full circle.











Notes:

- For lifting capacity including bucket, subtract total weight of bucket or bucket and quickhitch from above values.
- Lifting capacities are based on ISO 10567, that is: 75% of minimum tipping load or 87% of hydraulic lift capacity, whichever is the less. Lifting capacities marked* are based on hydraulic capacity.
- Lift capacities assume that the machine is on firm, level ground.
- Lift capacities may be limited by local regulations. Please refer to your dealer.











LIFT CAPACITIES – Dipper Length: 2.50m, 4.70m Monoboom, Front dozer, Rear stabiliser, No bucket.
JS145W MONO

Reach	3m (9ft 10in)		4m (13ft 1in)		5m (16ft 5in)		6m (19ft 8in)		Capacity at Max Reach		
	 kg	 kg	 kg	 kg	 kg	 kg	 kg	 kg	 kg	 kg	mm
Load Point Ht.											
6.0m (19ft 8in)			2850*	2850*	2990*	2990*			2290*	2290*	5828
5.0m (16ft 5in)			3160*	3160*	3110*	3110*	3130*	3130*	2190*	2190*	6424
4.0m (13ft 1in)	4420*	4420*	3780*	3780*	3440*	3440*	3260*	3260*	2160*	2160*	6821
3.0m (9ft 10in)	6110*	6110*	4600*	4600*	3880*	3880*	3490*	3490*	2180*	2180*	7053
2.0m (6ft 7in)	7700*	7700*	5430*	5430*	4360*	4360*	3760*	3590*	2260*	2260*	7136
1.0m (3ft 3in)	6200*	6200*	6050*	6050*	4750*	4590*	4000*	3530*	2400*	2400*	7076
0m	7380*	7380*	6380*	6330*	5010*	4520*	4150*	3490*	2620*	2620*	6869
- 1.0m (- 4ft 11in)	8560*	8560*	6410*	6290*	5060*	4490*	4130*	3470*	2970*	2970*	6501
- 2.0m (- 6ft 7in)	8030*	8030*	6130*	6130*	4840*	4500*			3590*	3550*	5940
- 3.0m (- 9ft 10in)	7060*	7060*	5420*	5420*	4090*	4090*			3900*	3900*	5124

LIFT CAPACITIES – Dipper Length: 2.50m, 4.70m Monoboom, Front stabiliser, Rear stabiliser, No bucket.
JS145W MONO

Reach	3m (9ft 10in)		4m (13ft 1in)		5m (16ft 5in)		6m (19ft 8in)		Capacity at Max Reach		
	 kg	 kg	 kg	 kg	 kg	 kg	 kg	 kg	 kg	 kg	mm
Load Point Ht.											
6.0m (19ft 8in)			2850*	2850*	2990*	2990*			2290*	2290*	5828
5.0m (16ft 5in)			3160*	3160*	3110*	3110*	3130*	3130*	2190*	2190*	6424
4.0m (13ft 1in)	4420*	4420*	3780*	3780*	3440*	3440*	3260*	3260*	2160*	2160*	6821
3.0m (9ft 10in)	6110*	6110*	4600*	4600*	3880*	3880*	3490*	3490*	2180*	2180*	7053
2.0m (6ft 7in)	7700*	7700*	5430*	5430*	4360*	4360*	3760*	3760*	2260*	2260*	7136
1.0m (3ft 3in)	6200*	6200*	6050*	6050*	4750*	4750*	4000*	3890*	2400*	2400*	7076
0m	7380*	7380*	6380*	6380*	5010*	5010*	4150*	3850*	2620*	2620*	6869
- 1.0m (- 4ft 11in)	8560*	8560*	6410*	6410*	5060*	4990*	4130*	3830*	2970*	2970*	6501
- 2.0m (- 6ft 7in)	8030*	8030*	6130*	6130*	4840*	4840*			3590*	3590*	5940
- 3.0m (- 9ft 10in)	7060*	7060*	5420*	5420*	4090*	4090*			3900*	3900*	5124

LIFT CAPACITIES – Dipper Length: 3.00m, 4.70m Monoboom, Rear dozer, No bucket.
JS145W MONO

Reach	3m (9ft 10in)		4m (13ft 1in)		5m (16ft 5in)		6m (19ft 8in)		Capacity at Max Reach		
	 kg	 kg	 kg	 kg	 kg	 kg	 kg	 kg	 kg	 kg	mm
Load Point Ht.											
6.0m (19ft 8in)					2590*	2590*	2800*	2730	2120*	2120*	6380
5.0m (16ft 5in)			2670*	2670*	2750*	2750*	2810*	2720	2050*	2050*	6928
4.0m (13ft 1in)			3290*	3290*	3100*	3100*	2990*	2680	2030*	1960	7297
3.0m (9ft 10in)	5220*	5220*	4130*	4130*	3580*	3420	3270*	2610	2050*	1850	7514
2.0m (6ft 7in)	6950*	6950*	5020*	4530	4100*	3290	3580*	2540	2120*	1790	7593
1.0m (3ft 3in)	7730*	6640*	5770*	4350	4560*	3190	3860*	2740	2240*	1790	7536
0m	7680*	6480	6250*	4230	4900*	3100	4080*	2420	2430*	1840	7342
- 1.0m (- 4ft 11in)	8720*	6420	6430*	4170	5060*	3060	4170*	2390	2720*	1950	6999
- 2.0m (- 6ft 7in)	8400*	6430	6320*	4150	4990*	3040	4040*	2390	3190*	2170	6483
- 3.0m (- 9ft 10in)	7680*	6500	5850*	4190	4580*	3070			3720*	2570	5746



Lift capacity front and rear.



Lift capacity full circle.

Notes:

- For lifting capacity including bucket, subtract total weight of bucket or bucket and quickhitch from above values.
- Lifting capacities are based on ISO 10567, that is: 75% of minimum tipping load or 87% of hydraulic lift capacity, whichever is the less. Lifting capacities marked* are based on hydraulic capacity.
- Lift capacities assume that the machine is on firm, level ground.
- Lift capacities may be limited by local regulations. Please refer to your dealer.

LIFT CAPACITIES – Dipper Length: 3.00m, 4.70m Monoboom, Rear stabilisers, No bucket.
JS145W MONO

Reach	3m (9ft 10in)		4m (13ft 1in)		5m (16ft 5in)		6m (19ft 8in)		Capacity at Max Reach		
											mm
Load Point Ht.	kg	kg	kg	kg	kg	kg	kg	kg	kg	kg	mm
6.0m (19ft 8in)					2590*	2590*	2800*	2800*	2120*	2120*	6380
5.0m (16ft 5in)			2670*	2670*	2750*	2750*	2810*	2810*	2050*	2050*	6928
4.0m (13ft 1in)			3290*	3290*	3100*	3100*	2990*	2990*	2030*	2030*	7297
3.0m (9ft 10in)	5220*	5220*	4130*	4130*	3580*	3580*	3270*	2950	2050*	2050*	7514
2.0m (6ft 7in)	6950*	6950*	5020*	5020*	4100*	3740	3580*	2880	2120*	2030	7593
1.0m (3ft 3in)	7730*	7730*	5770*	5010	4560*	3630	3860*	2810	2240*	2030	7536
0m	7680*	7650	6250*	4880	4900*	3550	4080*	2760	2430*	2090	7342
- 1.0m (- 4ft 11in)	8720*	7600	6430*	4820	5060*	3500	4170*	2720	2720*	2220	6999
- 2.0m (- 6ft 7in)	8400*	7610	6320*	4800	4990*	3490	4040*	2720	3190*	2470	6483
- 3.0m (- 9ft 10in)	7680*	7680	5850*	4840	4580*	3520			3720*	2930	5746

LIFT CAPACITIES – Dipper Length: 3.00m, 4.70m Monoboom, Front dozer, Rear stabilisers, No bucket.
JS145W MONO

Reach	3m (9ft 10in)		4m (13ft 1in)		5m (16ft 5in)		6m (19ft 8in)		Capacity at Max Reach		
											mm
Load Point Ht.	kg	kg	kg	kg	kg	kg	kg	kg	kg	kg	mm
6.0m (19ft 8in)					2590*	2590*	2800*	2800*	2120*	2120*	6380
5.0m (16ft 5in)			2670*	2670*	2750*	2750*	2810*	2810*	2050*	2050*	6928
4.0m (13ft 1in)			3290*	3290*	3100*	3100*	2990*	2990*	2030*	2030*	7297
3.0m (9ft 10in)	5220*	5220*	4130*	4130*	3580*	3580*	3270*	3270*	2050*	2050*	7514
2.0m (6ft 7in)	6950*	6950*	5020*	5020*	4100*	4100*	3580*	3580*	2120*	2120*	7593
1.0m (3ft 3in)	7730*	7730*	5770*	5770*	4560*	4560*	3860*	3560	2240*	2240*	7536
0m	7680*	7680*	6250*	6250*	4900*	4550	4080*	3510	2430*	2430*	7342
- 1.0m (- 4ft 11in)	8720*	8720*	6430*	6310	5060*	4500	4170*	3480	2720*	2720*	6999
- 2.0m (- 6ft 7in)	8400*	8400*	6320*	6300	4990*	4490	4040*	3470	3190*	3130	6483
- 3.0m (- 9ft 10in)	7680*	7680*	5850*	5850*	4580*	4520			3720*	3720*	5746

LIFT CAPACITIES – Dipper Length: 3.00m, 4.70m Monoboom, Front stabilisers, Rear stabilisers, No bucket.
JS145W MONO

Reach	3m (9ft 10in)		4m (13ft 1in)		5m (16ft 5in)		6m (19ft 8in)		Capacity at Max Reach		
											mm
Load Point Ht.	kg	kg	kg	kg	kg	kg	kg	kg	kg	kg	mm
6.0m (19ft 8in)					2590*	2590*	2800*	2800*	2120*	2120*	6380
5.0m (16ft 5in)			2670*	2670*	2750*	2750*	2810*	2810*	2050*	2050*	6928
4.0m (13ft 1in)			3290*	3290*	3100*	3100*	2990*	2990*	2030*	2030*	7297
3.0m (9ft 10in)	5220*	5220*	4130*	4130*	3580*	3580*	3270*	3270*	2050*	2050*	7514
2.0m (6ft 7in)	6950*	6950*	5020*	5020*	4100*	4100*	3580*	3580*	2120*	2120*	7593
1.0m (3ft 3in)	7730*	7730*	5770*	5770*	4560*	4560*	3860*	3860*	2240*	2240*	7536
0m	7680*	7680*	6250*	6250*	4900*	4900*	4080*	3870	2430*	2430*	7342
- 1.0m (- 4ft 11in)	8720*	8720*	6430*	6430*	5060*	5000	4170*	3840	2720*	2720*	6999
- 2.0m (- 6ft 7in)	8400*	8400*	6320*	6320*	4990*	4990	4040*	3830	3190*	3190*	6483
- 3.0m (- 9ft 10in)	7680*	7680*	5850*	5850*	4580*	4580*			3720*	3720*	5746



Lift capacity front and rear.



Lift capacity full circle.

Notes:

- For lifting capacity including bucket, subtract total weight of bucket or bucket and quickhitch from above values.
- Lifting capacities are based on ISO 10567, that is: 75% of minimum tipping load or 87% of hydraulic lift capacity, whichever is the less. Lifting capacities marked* are based on hydraulic capacity.
- Lift capacities assume that the machine is on firm, level ground.
- Lift capacities may be limited by local regulations. Please refer to your dealer.

LIFT CAPACITIES – Dipper Length: 2.10m, 5.00m T.A.B., Rear dozer, No bucket.
JSI45W T.A.B.

Reach	3m (9ft 10in)		4m (13ft 1in)		5m (16ft 5in)		6m (19ft 8in)		Capacity at Max Reach		
	kg	kg	kg	kg	kg	kg	kg	kg	kg	kg	mm
Load Point Ht.											
6.0m (19ft 8in)			3260*	3260*	3180*	3180*			2910*	2660*	5868
5.0m (16ft 5in)	4160*	4160*	3620*	3620*	3330*	3330*	3200*	2580	2720*	2260*	6461
4.0m (13ft 1in)	5490*	5490*	4250*	4250*	3640*	3350	3320*	2540	2640*	2040	6856
3.0m (9ft 10in)			5010*	4420	4050*	3220	3530*	2470	2630*	1910	7086
2.0m (6ft 7in)			5680*	4200	4440*	3090	3760*	2400	2670*	1850	7169
1.0m (3ft 3in)			6080*	4060	4740*	3000	3940*	2340	2770*	1860	7110
0m			6200*	4010	4880*	2950	4020*	2310	2970*	1930	6903
- 1.0m (- 4ft 11in)	6980*	6260	6060*	4010	4820*	2940	3930*	2310	3260*	2090	6537
- 2.0m (- 6ft 7in)	7160*	6340	5650*	4060	4510*	2970			3430*	2380	5980
- 3.0m (- 9ft 10in)											

LIFT CAPACITIES – Dipper Length: 2.10m, 5.00m T.A.B., Rear stabilisers, No bucket.
JSI45W T.A.B.

Reach	3m (9ft 10in)		4m (13ft 1in)		5m (16ft 5in)		6m (19ft 8in)		Capacity at Max Reach		
	kg	kg	kg	kg	kg	kg	kg	kg	kg	kg	mm
Load Point Ht.											
6.0m (19ft 8in)			3260*	3260*	3180*	3180*			2910*	2910*	5868
5.0m (16ft 5in)	4160*	4160*	3620*	3620*	3330*	3330*	3200*	2930	2720*	2570	6461
4.0m (13ft 1in)	5490*	5490*	4250*	4250*	3640*	3640*	3320*	2880	2640*	2320	6856
3.0m (9ft 10in)			5010*	5010*	4050*	3680	3530*	2810	2630*	2180	7086
2.0m (6ft 7in)			5680*	4870	4440*	3550	3760*	2740	2670*	2120	7169
1.0m (3ft 3in)			6080*	4730	4740*	3450	3940*	2690	2770*	2130	7110
0m			6200*	4670	4880*	3400	4020*	2650	2970*	2210	6903
- 1.0m (- 4ft 11in)	6980*	6980*	6060*	4670	4820*	3390	3930*	2650	3260*	2390	6537
- 2.0m (- 6ft 7in)	7160*	7160*	5650*	4720	4510*	3420			3430*	2720	5980
- 3.0m (- 9ft 10in)											

LIFT CAPACITIES – Dipper Length: 2.10m, 5.00m T.A.B., Front dozer, Rear stabilisers, No bucket.
JSI45W T.A.B.

Reach	3m (9ft 10in)		4m (13ft 1in)		5m (16ft 5in)		6m (19ft 8in)		Capacity at Max Reach		
	kg	kg	kg	kg	kg	kg	kg	kg	kg	kg	mm
Load Point Ht.											
6.0m (19ft 8in)			3260*	3260*	3180*	3180*			2910*	2910*	5868
5.0m (16ft 5in)	4160*	4160*	3620*	3620*	3330*	3330*	3200*	3200*	2720*	2720*	6461
4.0m (13ft 1in)	5490*	5490*	4250*	4250*	3640*	3320*	3640*	3320*	2640*	2640*	6856
3.0m (9ft 10in)			5010*	5010*	4050*	4050*	3530*	3530*	2630*	2630*	7086
2.0m (6ft 7in)			5680*	5680*	4440*	4440*	3760*	3510	2670*	2670*	7169
1.0m (3ft 3in)			6080*	6080*	4740*	4470	3940*	3450	2770*	2720	7110
0m			6200*	6180	4880*	4420	4020*	3420	2970*	2830	6903
- 1.0m (- 4ft 11in)	6980*	6980*	6060*	6060*	4820*	4410	3930*	3410	3260*	3060	6537
- 2.0m (- 6ft 7in)	7160*	7160*	5650*	5650*	4510*	4440			3430*	3430*	5980
- 3.0m (- 9ft 10in)											



Lift capacity front and rear.



Lift capacity full circle.

Notes:

- For lifting capacity including bucket, subtract total weight of bucket or bucket and quickhitch from above values.
- Lifting capacities are based on ISO 10567, that is: 75% of minimum tipping load or 87% of hydraulic lift capacity, whichever is the less. Lifting capacities marked* are based on hydraulic capacity.
- Lift capacities assume that the machine is on firm, level ground.
- Lift capacities may be limited by local regulations. Please refer to your dealer.

LIFT CAPACITIES – Dipper Length: 2.10m, 5.00m T.A.B., Front stabilisers, Rear stabilisers, No bucket.
JSI45W T.A.B.

Reach	3m (9ft 10in)		4m (13ft 1in)		5m (16ft 5in)		6m (19ft 8in)		Capacity at Max Reach		
											mm
Load Point Ht.	kg	kg	kg	kg	kg	kg	kg	kg	kg	kg	mm
6.0m (19ft 8in)			3260*	3260*	3180*	3180*			2910*	2910*	5868
5.0m (16ft 5in)	4160*	4160*	3620*	3620*	3330*	3330*	3200*	3200*	2720*	2720*	6461
4.0m (13ft 1in)	5490*	5490*	4250*	4250*	3640*	3640*	3320*	3320*	2640*	2640*	6856
3.0m (9ft 10in)			5010*	5010*	4050*	4050*	3530*	3530*	2630*	2630*	7086
2.0m (6ft 7in)			5680*	5680*	4440*	4440*	3760*	3760*	2670*	2670*	7169
1.0m (3ft 3in)			6080*	6080*	4740*	4740*	3940*	3820*	2770*	2770*	7110
0m			6200*	6200*	4880*	4880*	4020*	3780*	2970*	2970*	6903
- 1.0m (- 4ft 11in)	6980*	6980*	6060*	6060*	4820*	4820*	3930*	3780*	3260*	3260*	6537
- 2.0m (- 6ft 7in)	7160*	7160*	5650*	5650*	4510*	4510*			3430*	3430*	5980
- 3.0m (- 9ft 10in)											

LIFT CAPACITIES – Dipper Length: 2.50m, 5.00m T.A.B., Rear dozer, No bucket.
JSI45W T.A.B.

Reach	3m (9ft 10in)		4m (13ft 1in)		5m (16ft 5in)		6m (19ft 8in)		Capacity at Max Reach		
											mm
Load Point Ht.	kg	kg	kg	kg	kg	kg	kg	kg	kg	kg	mm
6.0m (19ft 8in)			2930*	2930*	2910*	2910*	2970*	2760*	2350*	2350*	6335
5.0m (16ft 5in)			3290*	3290*	3090*	3090*	2980*	2750*	2230*	2170*	6886
4.0m (13ft 1in)	4850*	4850*	3910*	3910*	3420*	3420*	3140*	2690*	2170*	1980*	7258
3.0m (9ft 10in)			4690*	4690*	3850*	3410*	3380*	2620*	2160*	1860*	7476
2.0m (6ft 7in)			5430*	4470*	4280*	3280*	3640*	2540*	2210*	1810*	7554
1.0m (3ft 3in)			5950*	4300*	4630*	3170*	3860*	2470*	2280*	1820*	7498
0m	4360*	4360*	6180*	4220*	4840*	3100*	3990*	2430*	2430*	1880*	7303
- 1.0m (- 4ft 11in)	6730*	6510*	6160*	4200*	4870*	3080*	3990*	2410*	2660*	2010*	6958
- 2.0m (- 6ft 7in)	7590*	6580*	5870*	4220*	4680*	3090*	3750*	2430*	3040*	2240*	6438
- 3.0m (- 9ft 10in)			5240*	4300*	4120*	3150*			3600*	2820*	5455

LIFT CAPACITIES – Dipper Length: 2.50m, 5.00m T.A.B., Rear stabilisers, No bucket.
JSI45W T.A.B.

Reach	3m (9ft 10in)		4m (13ft 1in)		5m (16ft 5in)		6m (19ft 8in)		Capacity at Max Reach		
											mm
Load Point Ht.	kg	kg	kg	kg	kg	kg	kg	kg	kg	kg	mm
6.0m (19ft 8in)			2930*	2930*	2910*	2910*	2970*	2970*	2350*	2350*	6335
5.0m (16ft 5in)			3290*	3290*	3090*	3090*	2980*	2980*	2230*	2230*	6886
4.0m (13ft 1in)	4850*	4850*	3910*	3910*	3420*	3420*	3140*	2930*	2170*	2150*	7258
3.0m (9ft 10in)			4690*	4690*	3850*	3730*	3380*	2850*	2160*	2030*	7476
2.0m (6ft 7in)			5430*	4950*	4280*	3600*	3640*	2770*	2210*	1970*	7554
1.0m (3ft 3in)			5950*	4780*	4630*	3490*	3860*	2700*	2280*	1980*	7498
0m	4360*	4360*	6180*	4690*	4840*	3420*	3990*	2660*	2430*	2040*	7303
- 1.0m (- 4ft 11in)	6730*	6730*	6160*	4670*	4870*	3390*	3990*	2640*	2660*	2190*	6958
- 2.0m (- 6ft 7in)	7590*	7590*	5870*	4700*	4680*	3400*	3750*	2660*	3040*	2450*	6438
- 3.0m (- 9ft 10in)			5240*	4780*	4120*	3470*			3600*	3100*	5455



Lift capacity front and rear.



Lift capacity full circle.

Notes:

- For lifting capacity including bucket, subtract total weight of bucket or bucket and quickhitch from above values.
- Lifting capacities are based on ISO 10567, that is: 75% of minimum tipping load or 87% of hydraulic lift capacity, whichever is the less. Lifting capacities marked* are based on hydraulic capacity.
- Lift capacities assume that the machine is on firm, level ground.
- Lift capacities may be limited by local regulations. Please refer to your dealer.

LIFT CAPACITIES – Dipper Length: 2.50m, 5.00m T.A.B., Front dozer, Rear stabilisers, No bucket.
JSI45W T.A.B.

Reach	3m (9ft 10in)		4m (13ft 1in)		5m (16ft 5in)		6m (19ft 8in)		Capacity at Max Reach		
	kg	kg	kg	kg	kg	kg	kg	kg	kg	kg	mm
Load Point Ht.											
6.0m (19ft 8in)			2930*	2930*	2910*	2910*	2970*	2970*	2350*	2350*	6335
5.0m (16ft 5in)			3290*	3290*	3090*	3090*	2980*	2980*	2230*	2230*	6886
4.0m (13ft 1in)	4850*	4850*	3910*	3910*	3420*	3420*	3140*	3140*	2170*	2170*	7258
3.0m (9ft 10in)			4690*	4690*	3850*	3850*	3380*	3380*	2160*	2160*	7476
2.0m (6ft 7in)			5430*	5430*	4280*	4280*	3640*	3540*	2210*	2210*	7554
1.0m (3ft 3in)			5950*	5950*	4630*	4510*	3860*	3470*	2280*	2280*	7498
0m	4360*	4360*	6180*	6180*	4840*	4440*	3990*	3420*	2430*	2430*	7303
- 1.0m (- 4ft 11in)	6730*	6730*	6160*	6160*	4870*	4410*	3990*	3410*	2660*	2660*	6958
- 2.0m (- 6ft 7in)	7590*	7590*	5870*	5870*	4680*	4420*	3750*	3430*	3040*	3040*	6438
- 3.0m (- 9ft 10in)			5240*	5240*	4120*	4120*			3600*	3600*	5455

LIFT CAPACITIES – Dipper Length: 2.50m, 5.00m T.A.B., Front stabilisers, Rear stabilisers, No bucket.
JSI45W T.A.B.

Reach	3m (9ft 10in)		4m (13ft 1in)		5m (16ft 5in)		6m (19ft 8in)		Capacity at Max Reach		
	kg	kg	kg	kg	kg	kg	kg	kg	kg	kg	mm
Load Point Ht.											
6.0m (19ft 8in)			2930*	2930*	2910*	2910*	2970*	2970*	2350*	2350*	6335
5.0m (16ft 5in)			3290*	3290*	3090*	3090*	2980*	2980*	2230*	2230*	6886
4.0m (13ft 1in)	4850*	4850*	3910*	3910*	3420*	3420*	3140*	3140*	2170*	2170*	7258
3.0m (9ft 10in)			4690*	4690*	3850*	3850*	3380*	3380*	2160*	2160*	7476
2.0m (6ft 7in)			5430*	5430*	4280*	4280*	3640*	3640*	2210*	2210*	7554
1.0m (3ft 3in)			5950*	5950*	4630*	4630*	3860*	3840*	2280*	2280*	7498
0m	4360*	4360*	6180*	6180*	4840*	4840*	3990*	3790*	2430*	2430*	7303
- 1.0m (- 4ft 11in)	6730*	6730*	6160*	6160*	4870*	4870*	3990*	3780*	2660*	2660*	6958
- 2.0m (- 6ft 7in)	7590*	7590*	5870*	5870*	4680*	4680*	3750*	3750*	3040*	3040*	6438
- 3.0m (- 9ft 10in)			5240*	5240*	4120*	4120*			3600*	3600*	5455

LIFT CAPACITIES – Dipper Length: 3.00m, 5.00m T.A.B., Rear dozer, No bucket.
JSI45W T.A.B.

Reach	3m (9ft 10in)		4m (13ft 1in)		5m (16ft 5in)		6m (19ft 8in)		Capacity at Max Reach		
	kg	kg	kg	kg	kg	kg	kg	kg	kg	kg	mm
Load Point Ht.											
6.0m (19ft 8in)					2580*	2580*	2650*	2650*	2180*	2130*	6896
5.0m (16ft 5in)			2870*	2870*	2780*	2780*	2730*	2700*	2080*	1880*	7405
4.0m (13ft 1in)	3910*	3910*	3480*	3480*	3140*	3140*	2920*	2640*	2040*	1730*	7751
3.0m (9ft 10in)			4270*	4270*	3590*	3350*	3190*	2560*	2040*	1640*	7956
2.0m (6ft 7in)			5080*	4390*	4060*	3200*	3480*	2470*	2070*	1600*	8030
1.0m (3ft 3in)			5720*	4190*	4470*	3080*	3740*	2400*	2140*	1600*	7977
0m	4660*	4660*	6090*	4070*	4760*	2990*	3940*	2340*	2270*	1640*	7794
- 1.0m (- 4ft 11in)	6340*	6210*	6200*	4020*	4880*	2950*	4010*	2310*	2460*	1740*	7472
- 2.0m (- 6ft 7in)	7990*	6250*	6060*	4020*	4810*	2940*	3920*	2310*	2770*	1910*	6991
- 3.0m (- 9ft 10in)	7290*	6340*	5620*	4070*	4460*	2980*	3500*	2350*	3110*	2220*	6315



Lift capacity front and rear.



Lift capacity full circle.

Notes:

- For lifting capacity including bucket, subtract total weight of bucket or bucket and quickhitch from above values.
- Lifting capacities are based on ISO 10567, that is: 75% of minimum tipping load or 87% of hydraulic lift capacity, whichever is the less. Lifting capacities marked* are based on hydraulic capacity.
- Lift capacities assume that the machine is on firm, level ground.
- Lift capacities may be limited by local regulations. Please refer to your dealer.

LIFT CAPACITIES – Dipper Length: 3.00m, 5.00m T.A.B., Rear stabilisers, No bucket.
JSI45W T.A.B.

Reach	3m (9ft 10in)		4m (13ft 1in)		5m (16ft 5in)		6m (19ft 8in)		Capacity at Max Reach		
											mm
Load Point Ht.	kg	kg	kg	kg	kg	kg	kg	kg	kg	kg	mm
6.0m (19ft 8in)					2580*	2580*	2650*	2650*	2180*	2180*	6896
5.0m (16ft 5in)			2870*	2870*	2780*	2780*	2730*	2730*	2080*	2080*	7405
4.0m (13ft 1in)	3910*	3910*	3480*	3480*	3140*	3140*	2920*	2920*	2040*	1970	7751
3.0m (9ft 10in)			4270*	4270*	3590*	3590*	3190*	2900	2040*	1870	7956
2.0m (6ft 7in)			5080*	5070	4060*	3660	3480*	2820	2070*	1820	8030
1.0m (3ft 3in)			5720*	4860	4470*	3540	3740*	2740	2140*	1820	7977
0m	4660*	4660*	6090*	4730	4760*	3450	3940*	2680	2270*	1870	7794
- 1.0m (- 4ft 11in)	6340*	6340*	6200*	4680	4880*	3400	4010*	2650	2460*	1980	7472
- 2.0m (- 6ft 7in)	7990*	7430	6060*	4680	4810*	3390	3920*	2650	2770*	2180	6991
- 3.0m (- 9ft 10in)	7290*	7290*	5620*	4730	4460*	3430	3500*	2690	3110*	2540	6315

LIFT CAPACITIES – Dipper Length: 3.00m, 5.00m T.A.B., Front dozer, Rear stabilisers, No bucket.
JSI45W T.A.B.

Reach	3m (9ft 10in)		4m (13ft 1in)		5m (16ft 5in)		6m (19ft 8in)		Capacity at Max Reach		
											mm
Load Point Ht.	kg	kg	kg	kg	kg	kg	kg	kg	kg	kg	mm
6.0m (19ft 8in)					2580*	2580*	2650*	2650*	2180*	2180*	6896
5.0m (16ft 5in)			2870*	2870*	2780*	2780*	2730*	2730*	2080*	2080*	7405
4.0m (13ft 1in)	3910*	3910*	3480*	3480*	3140*	3140*	2920*	2920*	2040*	2040*	7751
3.0m (9ft 10in)			4270*	4270*	3590*	3590*	3190*	3190*	2040*	2040*	7956
2.0m (6ft 7in)			5080*	5080*	4060*	4060*	3480*	3480*	2070*	2070*	8030
1.0m (3ft 3in)			5720*	5720*	4470*	4470*	3740*	3510	2140*	2140*	7977
0m	4660*	4660*	6090*	6090*	4760*	4470	3940*	3440	2270*	2270*	7794
- 1.0m (- 4ft 11in)	6340*	6340*	6200*	6190	4880*	4420	4010*	3410	2460*	2460*	7472
- 2.0m (- 6ft 7in)	7990*	7990*	6060*	6060*	4810*	4410	3920*	3410	2770*	2770*	6991
- 3.0m (- 9ft 10in)	7290*	7290*	5620*	5620*	4460*	4450	3500*	3460	3110*	3110*	6315

LIFT CAPACITIES – Dipper Length: 3.00m, 5.00m T.A.B., Front stabilisers, Rear stabilisers, No bucket.
JSI45W T.A.B.

Reach	3m (9ft 10in)		4m (13ft 1in)		5m (16ft 5in)		6m (19ft 8in)		Capacity at Max Reach		
											mm
Load Point Ht.	kg	kg	kg	kg	kg	kg	kg	kg	kg	kg	mm
6.0m (19ft 8in)					2590*	2590*	2800*	2800*	2120*	2120*	6380
5.0m (16ft 5in)			2670*	2670*	2750*	2750*	2810*	2810*	2050*	2050*	6928
4.0m (13ft 1in)			3290*	3290*	3100*	3100*	2990*	2990*	2030*	2030*	7297
3.0m (9ft 10in)	5220*	5220*	4130*	4130*	3580*	3580*	3270*	3270*	2050*	2050*	7514
2.0m (6ft 7in)	6950*	6590*	5020*	5020*	4100*	4100*	3580*	3580*	2120*	2120*	7593
1.0m (3ft 3in)	7730*	7730*	5770*	5770*	4560*	4560*	3860*	3860*	2240*	2240*	7536
0m	7680*	7680*	6250*	6250*	4900*	4900*	4080*	3870	2430*	2430*	7342
- 1.0m (- 4ft 11in)	8720*	8720*	6430*	6430*	5060*	5000	4170*	3840	2720*	2720*	6999
- 2.0m (- 6ft 7in)	8400*	8400*	6320*	6320*	4990*	4990	4040*	3830	3190*	3190*	6483
- 3.0m (- 9ft 10in)	7680*	7680*	5850*	5850*	4580*	4580*			3720*	3720*	5746



Lift capacity front and rear.



Lift capacity full circle.

Notes:

- For lifting capacity including bucket, subtract total weight of bucket or bucket and quickhitch from above values.
- Lifting capacities are based on ISO 10567, that is: 75% of minimum tipping load or 87% of hydraulic lift capacity, whichever is the less. Lifting capacities marked* are based on hydraulic capacity.
- Lift capacities assume that the machine is on firm, level ground.
- Lift capacities may be limited by local regulations. Please refer to your dealer.

A GLOBAL COMMITMENT TO QUALITY

JCB's total commitment to its products and customers has helped it grow from a one-man business into Britain's largest privately owned manufacturer of backhoe loaders, crawler excavators, wheeled excavators, telescopic handlers, wheeled loaders, dump trucks, rough terrain fork lifts, industrial fork lifts, mini/midi excavators, skid steer loaders, tractors and compaction equipment.

By making constant and massive investments in the latest production technology, the JCB factories have become some of the most advanced in the world.

By leading the field in innovative research and design, extensive testing and stringent quality control, JCB machines have become renowned all over the world for performance, value and reliability.

And with a global sales and service network of more than 650 dealers and agents, we aim to deliver the best customer support in the industry.

Through setting the standards by which others are judged, JCB has become one of the world's most impressive success stories.



JCB Sales Limited, Rokester, Staffordshire ST14 5JP. Tel: 01889 590312. Fax: 01889 590588. Web: <http://www.jcb.com>

JCB reserves the right to change specifications without notice. Illustrations shown may include optional equipment and accessories. The JCB logo is a registered trademark of J C Bamford Excavators Ltd.



9999/4980 02/12 Issue 5