

Robex

180w-9A

With Tier 4 Interim Engine installed

HYUNDAI HEAVY INDUSTRIES

MOVING YOU FURTHER



 **HYUNDAI**

PRIDE AT WORK

Hyundai Heavy Industries strives to build state-of-the-art earthmoving equipment to give every operator maximum performance, optimal controllability, versatile machine settings and proven technology.

Be proud of your work with Hyundai!



*Photo may include optional equipment.

Robex 180w-9A

Machine Walk-Around

Engine Technology

Proven, reliable, fuel efficient, low emission and low noise
Cummins Tier 4 interim & EU stage III B engine

Hydraulic System Improvements

New patented hydraulic control for improved controllability / Improved control valve design for added efficiency and smoother operation / New auto boom and swing priority system for optimum speed / New auto power boost feature for additional power when needed / Improved arm-in and boom-down flow regeneration system for added speed and efficiency

Pump Compartment

Industry-leading, powerful, reliable Kawasaki designed, variable volume in-line axial piston pumps
New compact solenoid block equipped with 3 solenoid valves, 1 EPPR valve, 1 check valve accumulator and pilot filter - controls 2 speed travel, power boost, boom priority, safety lock

Enhanced Operators' Cab

Improved Visibility

Enlarged cab with improved visibility / See-through upper skylight for visibility and ventilation
Larger right-side glass, now one piece, for better right visibility
Safety glass windows on all sides - less expensive than (polycarbonate) and won't scratch or fade
Closeable sunshade for operator convenience / Reduced front window seam for improved operator view

Rigid Cabin Construction

New steel tube construction for added operator safety, protection and durability
New window open/close mechanism designed with cable and spring lift assist and single latch release

Improved Seat & Console

Ergonomic joysticks with auxiliary control buttons for attachment use. Now with new sleek styling
Heated suspension (standard) or optional air ride suspension with heat
New joystick consoles - now adjustable in height by pushing the button
Integrated seat with consoles - reduce the operator fatigue

Advanced 7" Color Cluster with Touch Screen

New Color LCD Display with easy to read digital gauges for hydraulic oil temperature, water temperature, and fuel. Simplified design makes adjustment and diagnostics easier. Also, new enhanced features such as rear-view camera are integrated into monitor.
3 power modes : (P) Power, (S) Standard, (E) Economy, 2 work modes : Dig & Attachment, (U) User mode for operator preference
Enhanced self-diagnostic features with GPS download capability
One pump flow or two pump flow for optional attachment is now selectable through the cluster
New anti-theft system with password capability
Boom speed and arm regeneration are selectable through the monitor.
Auto power boost is now available - selectable (on/off) through the monitor.
Powerful air conditioning and heat with auto climate control
RMS (Remote Management System) works through GPS/satellite technology to ultimately provide better customer service and support.

Improved Steering Column

Slim-profile steering column capable of telescoping 60 mm and tilting 30 degrees



Specifications R180W-9A

ENGINE

MODEL	CUMMINS QSB6.7	
Type	Water cooled, 4 cycle Diesel, 6-Cylinders in line, direct injection, turbocharged, charged air cooled and low emission	
Rated flywheel horse power		
SAE	J1995 (gross)	165 HP (123 kW) / 2,200 rpm
	J1349 (net)	155 HP (115 kW) / 2,200 rpm
DIN	6271/1 (gross)	167 PS (123 kW) / 2,200 rpm
	6271/1 (net)	157 PS (115 kW) / 2,200 rpm
Max. torque	74.7 kgf.m (540 lbf.ft) / 1,500 rpm	
Bore x stroke	107 x 124 mm (4.21" x 4.88")	
Piston displacement	6,700 cc (409 in ³)	
Batteries	2 x 12 V x 100 AH	
Starting motor	24 V - 4.8 kW	
Alternator	24 V - 95 Amp	

HYDRAULIC SYSTEM

MAIN PUMP	
Type	Two variable displacement piston pumps
Max. flow	2 x 172 l/min (45.4 US gpm / 37.8 UK gpm)
Sub-pump for pilot circuit	Gear pump
Cross-sensing and fuel saving pump system	

HYDRAULIC MOTORS	
Travel	Variable displacement pistons motor with brake valve
Swing	Axial piston motor with automatic brake

RELIEF VALVE SETTING	
Implement circuits	350 kgf/cm ² (4,970 psi)
Travel	380 kgf/cm ² (5,400 psi)
Power boost (boom, arm, bucket)	380 kgf/cm ² (5,400 psi)
Swing circuit	285 kgf/cm ² (4,050 psi)
Pilot circuit	40 kgf/cm ² (570 psi)
Service valve	Installed

HYDRAULIC CYLINDERS	
No. of cylinder-bore x stroke	Boom : 2-115 x 1090 mm (4.5" x 42.9")
	Arm : 1-120 x 1355 mm (4.7" x 53.3")
	Bucket : 1-110 x 995 mm (4.3" x 39.2")
	Blade : 2-110 x 235 mm (4.3" x 9.3")
	Outrigger : 2-125 x 463 mm (4.9" x 18.2")
	2-PCS boom : 2-115 x 960 mm (4.1" x 37.8")
Adjust (boom) : 1-160 x 650 mm (6.3" x 25.6")	

DRIVES & BRAKES

4-wheel hydrostatic drive. Constant mesh, helical gear transmission provides 2 forward and reverse travel speeds.

Max. drawbar pull	11,000 kgf (24,250 lbf)	
Travel speed	1st	9.5 km/h
	2nd	35 km/h
Gradeability	35° (70 %)	

Parking brake : Independent dual brake, front and rear axle full hydraulic power brake.
 - Spring released and hydraulic applied wet type multiple disk brake.
 - Transmission is automatically locked at neutral position for parking.

CONTROL

Pilot pressure operated joysticks and pedals with detachable lever provide almost effortless and fatigueless operation.

Pilot control	Two joysticks with one safety lever (LH): Swing and arm (RH): Boom and bucket (ISO)
Engine throttle	Electric, Dial type

AXLE & WHEEL

Full floating front axle is supported by center pin for oscillation. It can be locked by oscillation lock cylinders. Rear axle is fixed on the lower chassis.

Tires	10.00 - 20 - 14PR, Dual (tube type)
(optional)	10.00 - 20, Dual (solid type)

SWING SYSTEM

Swing motor	Fixed displacement axial pistons motor
Swing reduction	Planetary gear reduction
Swing bearing lubrication	Grease-bathed
Swing brake	Multi wet disc (pin lock type)
Swing speed	9.1 rpm

STEERING SYSTEM

Hydraulically actuated, orbitrol type steering system actuates on front wheels through the steering cylinders.

Min. turning radius	6.3 m (20'8")
---------------------	---------------

COOLANT & LUBRICANT CAPACITY

	liter	US gal	UK gal	
Re-filling				
Fuel tank	270	71.3	59.4	
Engine coolant	19.5	5.2	4.3	
Engine oil	23.7	6.3	5.2	
Swing device - gear oil	5	1.3	1.1	
Axle	Front	15.5	4.1	3.4
	Rear	17.5	4.6	3.9
Hydraulic system (including tank)	270	71.3	59.4	
Hydraulic tank	160	42.3	35.2	

UNDERCARRIAGE

Reinforced box-section frame is all-welded, low-stress. Dozer blade and outriggers are available. A bolt-on design.

Dozer blade	A very useful addition for leveling and back filling or clean-up work.
Outrigger	Indicated for max. operation stability when digging and lifting. Can be mounted on the front / or the rear.

OPERATING WEIGHT (APPROXIMATE)

Operating weight, including 5,200 mm (17'1") Mono boom, 2,600 mm (8'6") arm, SAE heaped 0.76 m³ (0.99 yd³) backhoe bucket, lubricant, coolant, full fuel tank, full hydraulic tank and all standard equipments.

MAJOR COMPONENT WEIGHT	
Upperstructure	4,590 kg (10,120 lb)
Mono boom (with arm cylinder)	1,275 kg (2,810 lb)
Hydraulic adjustable boom (with adjust cylinder and arm cylinder)	1,780 kg (3,920 lb)

OPERATING WEIGHT		
Undercarriage	Mono boom	Hyd. adjustable boom
Rear dozer blade	17,280 kg (38,100 lb)	17,750 kg (39,130 lb)
Rear outrigger	17,430 kg (38,430 lb)	17,900 kg (39,460 lb)
Front outrigger and rear blade	18,400 kg (40,560 lb)	18,870 kg (41,600 lb)
Front blade and rear outrigger	18,340 kg (40,430 lb)	18,810 kg (41,470 lb)
Four outrigger	18,580 kg (40,960 lb)	19,050 kg (42,000 lb)

BUCKETS R180W-9A

All buckets are welded with high-strength steel.



0.39 (0.51)



0.50 (0.65)



0.64 (0.84)



0.76 (0.99)



0.89 (1.16)



1.05 (1.37)



● 0.69 (0.90)

SAE heaped m³ (yd³)

Capacity m ³ (yd ³)		Width mm (in)		Weight kg (lb)	Recommendation m (ft.in)				
SAE heaped	CECE heaped	Without side cutters	With side cutters		5.2 (17' 1") Mono Boom			5.1 (16' 1") Hydraulic Adjustable Boom	
					2.2 (7' 3") Arm	2.6 (8' 6") Arm	3.1 (10' 2") Arm	2.2 (7' 3") Arm	2.6 (8' 6") Arm
0.39 (0.51)	0.34 (0.44)	620 (24.4)	740 (29.1)	410 (900)	●	●	●	●	●
0.50 (0.65)	0.44 (0.58)	760 (29.9)	880 (34.6)	470 (1040)	●	●	●	●	●
0.64 (0.84)	0.55 (0.72)	920 (36.2)	1,040 (40.9)	510 (1120)	■	■	▲	■	■
0.76 (0.99)	0.65 (0.85)	1,060 (41.7)	1,180 (46.5)	570 (1260)	■	▲	▲	■	▲
0.89 (1.16)	0.77 (1.01)	1,220 (48.0)	1,340 (52.8)	610 (1340)	▲	▲	-	▲	▲
1.05 (1.37)	0.90 (1.18)	1,400 (55.1)	1,520 (59.8)	680 (1500)	▲	-	-	▲	-
● 0.69 (0.90)	0.62 (0.81)	990 (39.0)	-	700 (1540)	■	▲	▲	■	▲

● Heavy duty bucket

Note: Dozer Blade down

● : Applicable for materials with density of 2,000 kg/m³ (3,370 lb/yd³) or less

■ : Applicable for materials with density of 1,600 kg/m³ (2,700 lb/yd³) or less

▲ : Applicable for materials with density of 1,100 kg/m³ (1,850 lb/yd³) or less

ATTACHMENT R180W-9A

Booms and arms are welded, a low-stress, full-box section design.

5.2 m (17' 1") boom & 5.1 m (16' 1") Hydraulic Adjustable Boom and 2.2 m (7' 3"); 2.6 m (8' 6") & 3.1 m (10' 2") arms are available.

DIGGING FORCE R180W-9A

Boom	Length	mm (ft.in)	5,200 (17' 1")			Remarks
	Weight	kg (lb)	1,240 (2,730)			
Arm	Length	mm (ft.in)	2,200 (7' 3")	2,600 (8' 6")	3,100 (10' 2")	[]: Power Boost
	Weight	kg (lb)	750 (1,560)	810 (1,790)	890 (1,960)	
Bucket digging force	SAE	kN	107.9 [117.2]	107.9 [117.2]	107.9 [117.2]	
		kgf	11,000 [11,940]	11,000 [11,940]	11,000 [11,940]	
		lbf	24,250 [26,330]	24,250 [26,330]	24,250 [26,330]	
	ISO	kN	123.6 [134.2]	123.6 [134.2]	123.6 [134.2]	
		kgf	12,600 [13,680]	12,600 [13,680]	12,600 [13,680]	
		lbf	27,780 [30,160]	27,780 [30,160]	27,780 [30,160]	
Arm crowd force	SAE	kN	87.2 [94.7]	77.3 [83.9]	77.3 [83.9]	
		kgf	8,890 [9,650]	7,880 [8,560]	7,880 [8,560]	
		lbf	19,600 [21,280]	17,270 [18,860]	17,270 [18,860]	
	ISO	kN	91.0 [98.8]	80.3 [87.2]	80.3 [87.2]	
		kgf	9,280 [10,080]	8,190 [8,890]	8,190 [8,890]	
		lbf	20,460 [22,210]	18,060 [19,600]	18,060 [19,600]	

Note: Boom weight includes arm cylinder, piping and pin

Arm weight includes bucket cylinder, linkage and pin

Dimensions & Working Ranges

DIMENSIONS R180W-9A

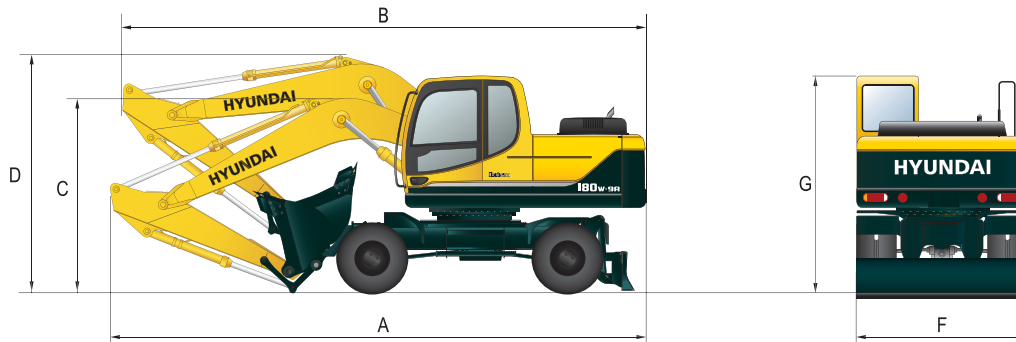

mm (ft · in)

Mono Boom		5,200 (17' 1")		
Arm	2,200 (7' 3")	2,600 (8' 6")	3,100 (11' 1")	
A Overall length of shipping position	8,650 (28' 5")	8,760 (28' 9")	8,760 (28' 9")	
B Overall length of traveling position	8,590 (28' 2")	8,710 (28' 7")	8,480 (27' 10")	
C Height of attachment (shipping position)	3,060 (10' 0")	3,180 (10' 6")	3,150 (10' 4")	
D Height of attachment (traveling position)	3,610 (11' 10")	3,540 (11' 8")	3,900 (12' 10")	
F Overall width	2,500 (8' 2")	2,500 (8' 2")	2,500 (8' 2")	
G Height of cabin	3,190 (10' 6")	3,190 (10' 6")	3,190 (10' 6")	

WORKING RANGES R180W-9A

mm (ft · in)

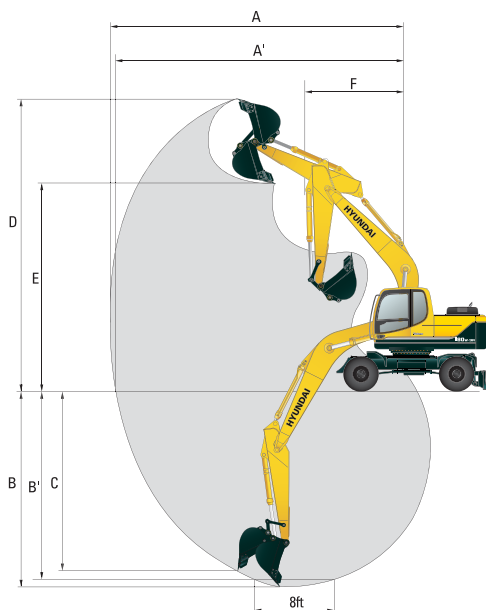

Boom length		5,200 (17' 1")		
Arm length	2,200 (7' 3")	2,600 (8' 6")	3,100 (10' 2")	
A Max. digging reach	8,820 (29' 1")	9,200 (30' 3")	9,450 (31' 0")	
A' Max. digging reach on ground	8,615 (28' 4")	9,000 (29' 7")	9,250 (30' 4")	
B Max. digging depth	5,500 (18' 2")	5,900 (19' 5")	6,320 (20' 9")	
B' Max. digging depth (8' level)	5,280 (17' 5")	5,700 (18' 9")	6,130 (20' 1")	
C Max. vertical wall digging depth	4,850 (16' 1")	5,310 (17' 6")	5,470 (17' 11")	
D Max. digging height	9,180 (30' 3")	9,300 (30' 7")	9,220 (30' 3")	
E Max. dumping height	6,520 (21' 5")	6,660 (21' 8")	6,620 (21' 9")	
F Min. front swing radius	3,290 (10' 9")	3,230 (10' 8")	3,160 (10' 4")	

Dimensions & Working Ranges



DIMENSIONS R180W-9A ADJUSTABLE BOOM

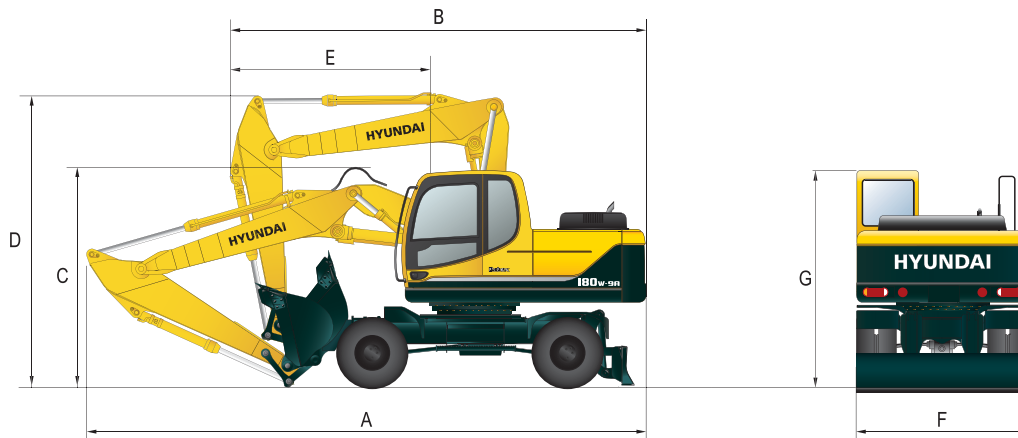

mm (ft · in)

	5,200 (17'1")	
Hydraulic adjustable boom		
Arm	2,200 (7'3")	2,600 (8'6")
A Overall length of shipping position	8,650 (28'5")	8,750 (28'8")
B Overall length of traveling position	6,630 (21'9")	6,620 (21'9")
C Height of attachment (shipping position)	2,900 (9'6")	2,920 (9'7")
D Height of attachment (traveling position)	3,980 (13'1")	3,960 (13'0")
E End of attachment to steering wheel	3,300 (10'10")	3,290 (10'10")
F Overall width	2,500 (8'2")	2,500 (8'2")
G Height of cabin	3,190 (10'6")	3,190 (10'6")

WORKING RANGES R180W-9A ADJUSTABLE BOOM

mm (ft · in)

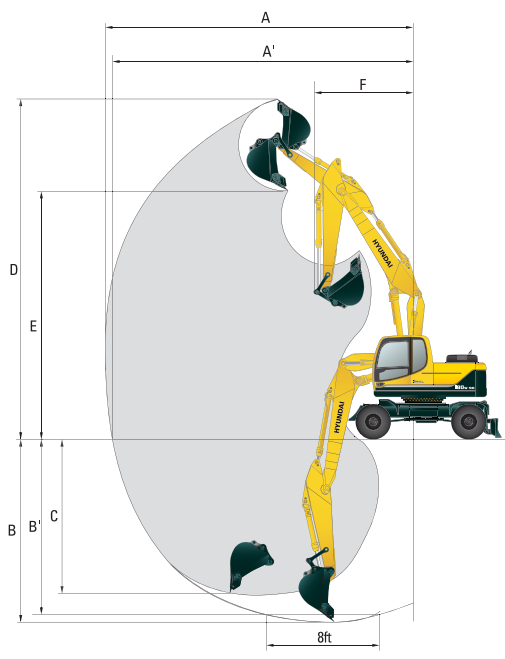

	5,200 (17'1")	
Boom length		
Arm length	2,200 (7'3")	2,600 (8'6")
A Max. digging reach	8,760 (28'9")	9,110 (29'11")
A' Max. digging reach on ground	8,550 (28'1")	8,910 (29'3")
B Max. digging depth	5,220 (17'2")	5,620 (18'5")
B' Max. digging depth (8' level)	5,120 (16'10")	5,520 (18'1")
C Max. vertical wall digging depth	4,430 (14'6")	4,780 (15'8")
D Max. digging height	9,630 (31'7")	9,820 (32'3")
E Max. dumping height	6,930 (22'9")	7,130 (23'5")
F Min. front swing radius	3,100 (10'2")	2,970 (9'9")

Undercarriage

R180W-9A WITH REAR DOZER AND FRONT REST

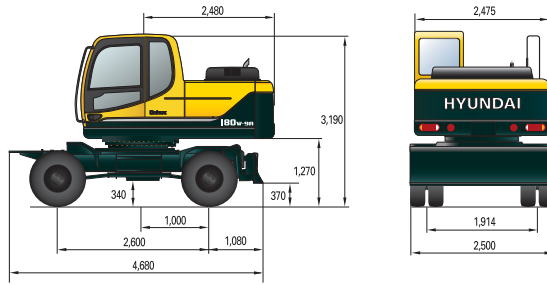

R180W-9A WITH REAR OUTRIGGER AND FRONT REST

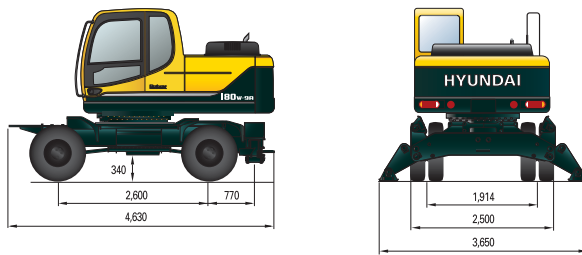

R180W-9A WITH REAR DOZER AND FRONT OUTRIGGER

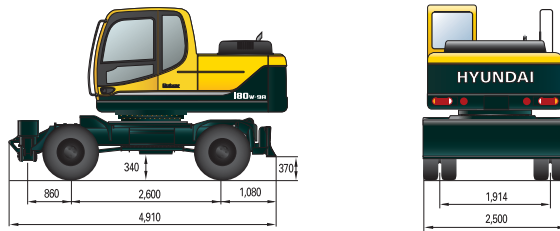

R180W-9A WITH REAR AND FRONT OUTRIGGER

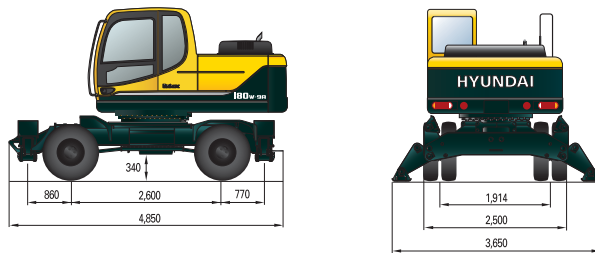

R180W-9A WITH REAR OUTRIGGER AND FRONT DOZER

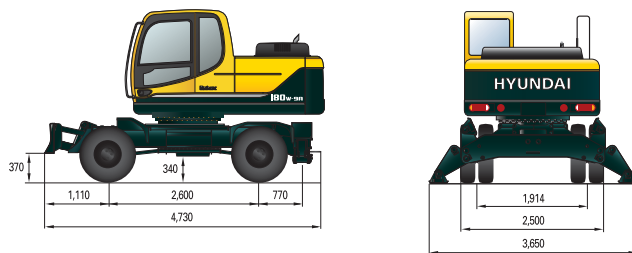

Lifting Capacities



R180W-9A MONO BOOM

Rating over-front Rating over-side or 360 degrees

Boom : 5.2 m (17' 1") / Arm : 2.2 m (7' 3") / Bucket : 0.76 m³ (0.99 yd³) SAE heaped / Dozer blade down with 3,150 kg counterweight

Load point height m (ft)	Load radius										At max. reach							
	1.5 m (5 ft)		3.0 m (10 ft)		4.5 m (15 ft)		6.0 m (20 ft)		7.5 m (25 ft)		Capacity		Reach					
													m (ft)					
7.5 m (25 ft)	kg											*3680	3080	6.09				
6.0 m (20 ft)	kg							*3630	3080			*8110	6790	(20.0)				
4.5 m (15 ft)	kg							*8000	6790			*3630	1790	8.00				
3.0 m (10 ft)	kg							*4750	*4750	*4130	3010	*9110	6640	*8000	3950	(26.2)		
1.5 m (5 ft)	kg							*6020	4520	*4660	2860	*2670	1920	3560	1610	8.32		
Ground Line	kg							*13270	9960	*10270	6310	*5890	4230	7850	3550	(27.3)		
-1.5 m (-5 ft)	kg							*7180	4170	*5210	2700	*3480	1860	3520	1570	8.33		
-3.0 m (-10 ft)	kg							*15830	9190	*11490	5950	*7670	4100	7760	3460	(27.3)		
Ground Line	kg							*7120	*7120	*7680	3990	*5510	2590	3720	1660	8.01		
-1.5 m (-5 ft)	kg							*15700	*15700	*16930	8800	*12150	5710	8200	3660	(26.3)		
-3.0 m (-10 ft)	kg							*7410	*7410	*10980	7610	*7470	3950	*5370	2560	*3810	1940	7.34
-4.5 m (-15 ft)	kg							*16340	*16340	*24210	16780	*16470	8710	*11840	5640	*8400	4280	(24.1)
-6.0 m (-20 ft)	kg							*11630	*11630	*9190	7790	*6420	4030		*3510	2650	6.15	
-7.5 m (-25 ft)	kg							*25640	*25640	*20260	17170	*14150	8880		*7740	5840	(20.2)	

Boom : 5.2 m (17' 1") / Arm : 2.6 m (8' 6") / Bucket : 0.76 m³ (0.99 yd³) SAE heaped / Dozer blade down with 3,150 kg counterweight

Load point height m (ft)	Load radius										At max. reach							
	1.5 m (5 ft)		3.0 m (10 ft)		4.5 m (15 ft)		6.0 m (20 ft)		7.5 m (25 ft)		Capacity		Reach					
													m (ft)					
7.5 m (25 ft)	kg											*3340	2710	6.57				
6.0 m (20 ft)	kg							*3380	3130			*7360	5970	(21.6)				
4.5 m (15 ft)	kg							*7450	6900			*3320	1970	7.70				
3.0 m (10 ft)	kg							*3800	3030	*1830	*1830	*7320	4340	(25.3)				
1.5 m (5 ft)	kg							*8380	6680	*4030	*4030	*3360	1640	8.35				
Ground Line	kg							*4380	2860	*3290	1920	3320	1470	8.66				
-1.5 m (-5 ft)	kg							*19250	19220	*12260	10080	*9660	6310	*7250	4230	7320	3240	(28.4)
-3.0 m (-10 ft)	kg							*6780	*6780	*6840	4180	*4990	2680	*4070	1840	3270	1430	8.67
-4.5 m (-15 ft)	kg							*14950	*14950	*15080	9220	*11000	5910	*8970	4060	7210	3150	(28.4)
Ground Line	kg							*7720	7470	*7540	3950	*5400	2550	*3830	1780	3430	1500	8.37
-1.5 m (-5 ft)	kg							*17020	16470	*16620	8710	*11900	5620	*8440	3920	7560	3310	(27.5)
-3.0 m (-10 ft)	kg							*7000	*7000	*10750	7480	*7530	3880	*5400	2500	*3670	1730	7.73
-4.5 m (-15 ft)	kg							*15430	*15430	*23700	16490	*16600	8550	*11900	5510	*8090	3810	(25.4)
-6.0 m (-20 ft)	kg							*10290	*10290	*9880	7620	*6750	3920	*4710	2540	*3540	2280	6.63
-7.5 m (-25 ft)	kg							*22690	*22690	*21780	16800	*14880	8640	*10380	5600	*7800	5030	(21.8)

Boom : 5.2 m (17' 1") / Arm : 3.1 m (10' 2") / Bucket : 0.76 m³ (0.99 yd³) SAE heaped / Dozer blade down with 3,150 kg counterweight

Load point height m (ft)	Load radius										At max. reach									
	1.5 m (5 ft)		3.0 m (10 ft)		4.5 m (15 ft)		6.0 m (20 ft)		7.5 m (25 ft)		Capacity		Reach							
													m (ft)							
7.5 m (25 ft)	kg											*1940	*1940		*2980	2320	7.16			
6.0 m (20 ft)	kg							*4280	*4280			*6570	5110	(23.5)						
4.5 m (15 ft)	kg							*3030	*3030			*3000	1740	8.20						
3.0 m (10 ft)	kg							*6680	*6680			*6610	3840	(26.9)						
1.5 m (5 ft)	kg							*3400	3060	*2490	2000	*3060	1460	8.81						
Ground Line	kg							*7500	6750	*5490	4410	*6750	3220	(28.9)						
-1.5 m (-5 ft)	kg							*7340	*7340	*4970	4650	*4020	2880	*3380	1920	3030	1310	9.10		
-3.0 m (-10 ft)	kg							*16180	*16180	*10960	10250	*8860	6350	*7450	4230	6680	2890	(29.9)		
-4.5 m (-15 ft)	kg							*9440	7930	*6380	4230	*4700	2680	*3860	1820	2980	1270	9.11		
-6.0 m (-20 ft)	kg							*20810	17480	*14070	9330	*10360	5910	*8510	4010	6570	2800	(29.9)		
-7.5 m (-25 ft)	kg							*8250	7460	*7300	3940	*5220	2530	4020	1740	3110	1320	8.83		
-9.0 m (-30 ft)	kg							*18190	16450	*16090	8690	*11510	5580	8860	3840	6860	2910	(29.0)		
-10.5 m (-35 ft)	kg							*6520	*6520	*10260	7370	*7530	3820	*5380	2440	*3370	1710	*3450	1500	8.23
-12.0 m (-40 ft)	kg							*14370	*14370	*22620	16250	*16600	8420	*11860	5380	*7430	3770	*7610	3310	(27.0)
-13.5 m (-45 ft)	kg							*9180	*9180	*10560	7460	*7040	3820	*4990	2440	*3450	1920	7.21		
-15.0 m (-50 ft)	kg							*20240	*20240	*23280	16450	*15520	8420	*11000	5380	*7610	4230	(23.7)		
-16.5 m (-55 ft)	kg							*12710	*12710	*8140	7710	*5470	3960		*3050	*3050	5.51			
-18.0 m (-60 ft)	kg							*28020	*28020	*17950	17000	*12060	8730		*6720	*6720	(18.1)			













- Lifting capacity is based on SAE J1097, ISO 10567.
- Lifting capacity of the Robex Series does not exceed 75% of the tipping load with the machine on firm, level ground or 87% of full hydraulic capacity.
- The load point is a hook located on the back of the bucket.
- (*) indicates the load limited by hydraulic capacity.

Lifting Capacities













R180W-9A ADJUSTABLE BOOM

 Rating over-front  Rating over-side or 360 degrees

Boom : 5.1 m (16'9") / Arm : 2.2 m (7'3") / Bucket : 0.76 m³ (0.99 yd³) SAE heaped / Dozer blade down with 3,150 kg counterweight

Load point height m (ft)		Load radius										At max. reach			
		1.5 m (5 ft)		3.0 m (10 ft)		4.5 m (15 ft)		6.0 m (20 ft)		7.5 m (25 ft)		Capacity		Reach m (ft)	
															
6.0 m (20 ft)	kg												*3710	2210	7.22
	lb												*8180	4870	(23.7)
4.5 m (15 ft)	kg							*4210	3020				*3680	1810	7.92
	lb							*9280	6660				*8110	3990	(26.0)
3.0 m (10 ft)	kg					*6040	4550	*4690	2860				3660	1620	8.25
	lb					*13320	10030	*10340	6310				8070	3570	(27.1)
1.5 m (5 ft)	kg					*7120	4180	*5190	2700	*3430	1820		3610	1590	8.26
	lb					*15700	9220	*11440	5950	*7560	4080		7960	3510	(27.1)
Ground Line	kg			*6770	*6770	*7590	3980	*5450	2580				*3750	1680	7.94
	lb			*14930	*14930	*16730	8770	*12020	5690				*8270	3700	(26.0)
-1.5 m (-5 ft)	kg	*6880	*6880	*10730	7600	*7310	3940	*5230	2560				*3640	1980	7.26
	lb	*15170	*15170	*23660	16760	*16120	8690	*11530	5640				*8020	4370	(23.8)
-3.0 m (-10 ft)	kg			*8720	7820	*6110	4040						*3140	2750	6.05
	lb			*19220	17240	*13470	8910						*6920	6060	(19.8)

Boom : 5.1 m (16'9") / Arm : 2.6 m (8'6") / Bucket : 0.76 m³ (0.99 yd³) SAE heaped / Dozer blade down with 3,150 kg counterweight

Load point height m (ft)		Load radius										At max. reach			
		1.5 m (5 ft)		3.0 m (10 ft)		4.5 m (15 ft)		6.0 m (20 ft)		7.5 m (25 ft)		Capacity		Reach m (ft)	
															
6.0 m (20 ft)	kg												*3410	2000	7.63
	lb												*7520	4410	(25.0)
4.5 m (15 ft)	kg												*3410	1650	8.29
	lb												*7520	3640	(27.2)
3.0 m (10 ft)	kg							*4420	2870	*3380	1910		3400	1480	8.60
	lb							*9740	6330	*7450	4210		7500	3260	(28.2)
1.5 m (5 ft)	kg			*6600	*6600	*6800	4200	*4980	2680	*4050	1830		3350	1440	8.61
	lb			*14550	*14550	*14990	9260	*10980	5910	*8930	4030		7390	3170	(28.2)
Ground Line	kg			*7410	*7410	*7460	3950	*5340	2550	*3830	1780		3530	1520	8.31
	lb			*16340	*16340	*16450	8710	*11770	5620	*8440	3920		7780	3350	(27.3)
-1.5 m (-5 ft)	kg	*6550	*6550	*10600	7470	*7390	3870	*5290	2490				*3520	1760	7.66
	lb	*14440	*14440	*23370	16470	*16290	8530	*11660	5490				*7760	3880	(25.1)
-3.0 m (-10 ft)	kg	*10160	*10160	*9480	7640	*6500	3930	*4440	2550				*3240	2350	6.54
	lb	*22400	*22400	*20900	16840	*14330	8660	*9790	5620				*7140	5180	(21.5)
-4.5 m (-15 ft)	kg			*6100	*6100	*3870	*3870								
	lb			*13450	*13450	*8530	*8530								

- Lifting capacity is based on SAE J1097, ISO 10567.
- Lifting capacity of the Robex Series does not exceed 75% of the tipping load with the machine on firm, level ground or 87% of full hydraulic capacity.
- The load point is a hook located on the back of the bucket.
- (*) indicates the load limited by hydraulic capacity.

STANDARD EQUIPMENT R180W-9A

ISO Standard cabin

All-weather steel cab with 360° visibility
 Safety glass windows
 Rise-up type windshield wiper
 Sliding fold-in front window
 Sliding side window (LH)
 One key fits all lockable doors
 Hot & cool box
 Storage compartment & Ashtray
 Transparent cabin roof-cover
 Radio / MP3 Player with remote control and USB-input
 Handsfree mobile phone system with USB-charging device
 12 volt power outlet (24V DC to 12V DC converter)
 Sun visor

Boom

5.2m; 17' 1"

Computer aided power optimization (CAPO) system

3-power modes, 2-work modes, User mode
 Auto & one-touch deceleration system
 Auto warm-up system
 Overheat prevention system

Automatic temperature control

Air conditioner & heater
 Defroster

Self-diagnostics system

Starting Aid (air grid heater) for cold weather

Centralized monitoring

LCD display
 Engine speed or Trip meter
 Clock
 Gauges
 - Fuel level gauge
 - Engine coolant temperature gauge
 - Hyd. oil temperature gauge
 Warning lamps
 - Engine warning
 - Overload
 - Communication error
 - Low battery
 - Air filter clogging
 Indicators
 - Max power
 - Low speed/High speed
 - Fuel warmer
 - Auto deceleration

Two outside rearview mirrors

Adjustable air suspension seat with heater

Adjustable joysticks

Console box height adjust system

Four frontal working lights

Electric horn

Batteries (2 x 12V x 100 AH)

Battery master switch

Removable clean-out screen for coolers

Automatic swing brake

Removable reservoir tank

Fuel pre-filter with fuel warmer

Boom holding system

Arm holding system

Accumulator for lowering work equipment

Electric transducer

Lower frame under cover

Viscous fan clutch

Rear-blade (550 mm x 2,500 mm)

Dual tires (10.00-20-14PR)

Travel alarm

OPTIONAL EQUIPMENT R180W-9A

Fuel filler pump (35 ℓ/min)

Beacon lamp

Safety lock valve for boom cylinder with overload warning device

Safety lock valve for arm cylinder

Single-acting piping kit (breaker, etc.)

Double-acting piping kit (clamshell, etc.)

Quick coupler

Arms

2.2 m; 7' 3"

2.6 m; 8' 6"

3.1 m; 10' 2"

Climate control

Air conditioner only

Heater only

Cabin FOPS/FOG (ISO/DIS 10262 Level II)

FOPS (Falling Object Protective Structure)

FOG (Falling Object Guard)

Cabin ROPS (ISO 12117-2)

ROPS (Roll Over Protective Structure)

Cabin roof-steel cover

Cabin front guard-wire net

Cabin guard front

Wire net

Fine net

Cabin lights

Cabin rain guard - front window

Undercarriage

Rear outriggers

Rear dozer and front outriggers

Rear and front outriggers

Rear outriggers and front dozer

Additional lower frame - reinforced under cover

Tool kit

Rearview camera

Seat

Mechanical suspension seat with heater

Dual tires - solid (10.00 - 20)

Fenders (Mudguards)

Pattern change valve (2 patterns)

Hi-mate (Remote Management System)

Company Organization

Hyundai Heavy Industries (HHI) had its groundbreaking ceremony in March 1972. HHI spreads across 2,300 acres that cover 1,500 acres of its production facilities and 800 acres of amenities (apartment complexes, schools, and recreational centers). Since the successful construction of its first two 260,000 DWT supertankers in 1974, HHI has built and delivered almost every kind of ship to customers the world over. Backed by technology and experience acquired through shipbuilding as well as streamlined modern facilities and a highly skilled work force, HHI has diversified its business activities from shipbuilding into other heavy industrial fields. On this vast compound, HHI operates various business lines: Shipbuilding, Engine & Machinery, Offshore & Engineering, Industrial Plant & Engineering, Electro Electric Systems, Construction Equipment and Green Energy, ISO 9001 & ISO 14001 certified.



Shipbuilding Division



Construction Equipment Division



Offshore & Engineering Division



Engine & Machinery Division



Electro Electric Systems Division



Industrial Plant & Engineering Division



Green Energy Division

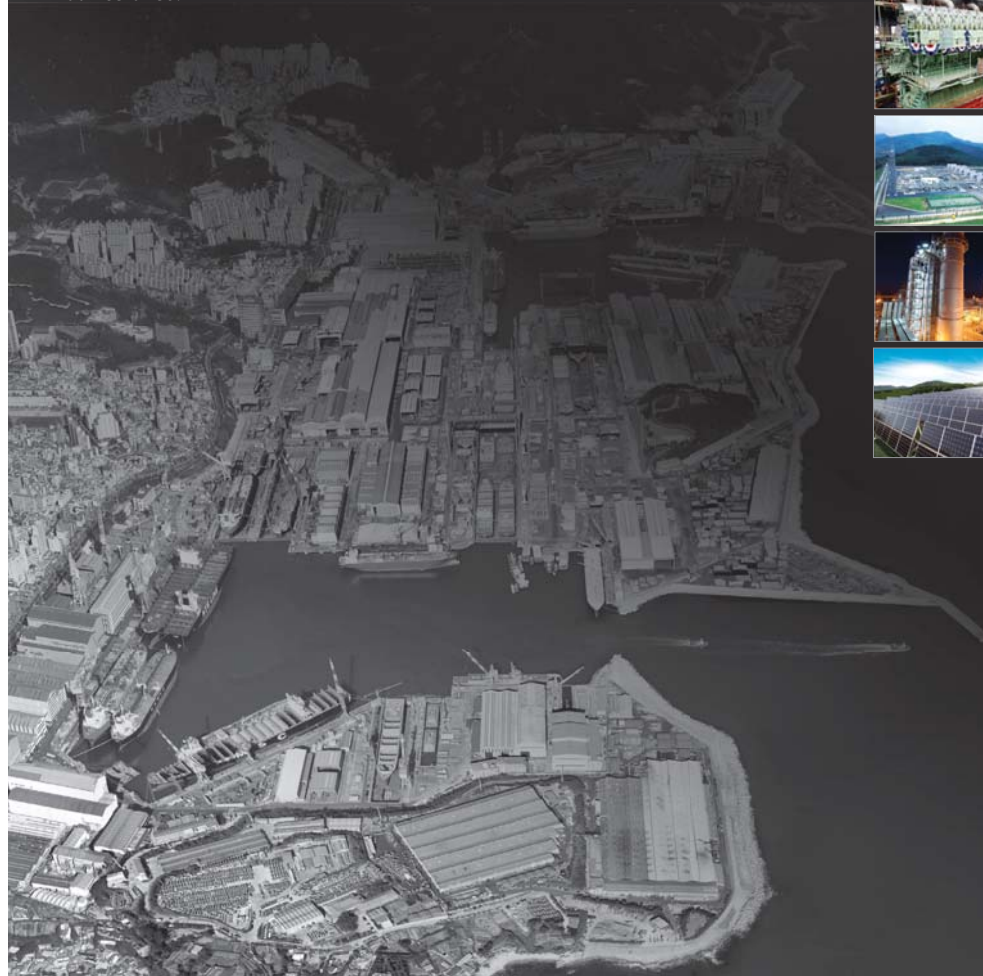

- * Standard and optional equipment may vary. Contact your Hyundai dealer for more information. The machine may vary according to international standards.
- * The photos may include attachments and optional equipment that are not available in your area.
- * Materials and specifications are subject to change without advance notice.
- * All imperial measurements rounded off to the nearest pound or inch.

PLEASE CONTACT

 **HYUNDAI**
HEAVY INDUSTRIES EUROPE
CONSTRUCTION EQUIPMENT

www.hyundai.eu

EN - 2013.03 Rev 0

Hyundai Heavy Industries Europe N.V.
VOSSENDAAL 11, 2440 GEEL, BELGIUM TEL: (32) 14-56-2200 FAX: (32) 14-59-3405