

Standard Features

Engine

- Auto Engine Shutdown (after 5 mins idling)
- Auto Engine Idling System
- LED Engine Instrumentation

Hydraulic

- Joystick Operation with Proportional Control (PTO and Boom Swing)
- Joystick Operation ISO Pattern
- PTO Piping
- Boom Cylinder Protection
- Circuit Identification
- Cushioned Cylinders
- Double Acting Hydraulic Circuit

Cab

- Adjustable Heater
- Fully Adjustable Fabric Suspension Seat
- Moulded Floor Mat
- Integrated Seatbelt
- Arm & Wrist Support
- Cab Harness for Light/Beacon
- Ashtray
- 12V Power Socket
- Emergency Break Glass Hammer
- Cab Light
- Pre-wired for Radio Installation
- Protected Drive Light
- Cup Holder
- LED Immobilizer Light

Attachment

- Standard Arm
- Boom Light
- Boom Lowering Valve

Track

- Short Pitch Rubber Tracks
- Two-Speed Travel
- Straight Line Travel

Other

- Essential Tool Kit

Optional Extras

Cab

- PVC Seat
- Air Conditioning/De-humidifier
- AM/FM Radio, Mono Speaker

Attachment

- Long Arm
- Quick Hitch
- Boom Anti-drop Valve
- Arm Anti-drop Valve

Track

- Steel Crawler
- Steel Crawler Pads

Other

- Breaker
- Extra counterweight
- Tilt-Rotator
- Immobiliser

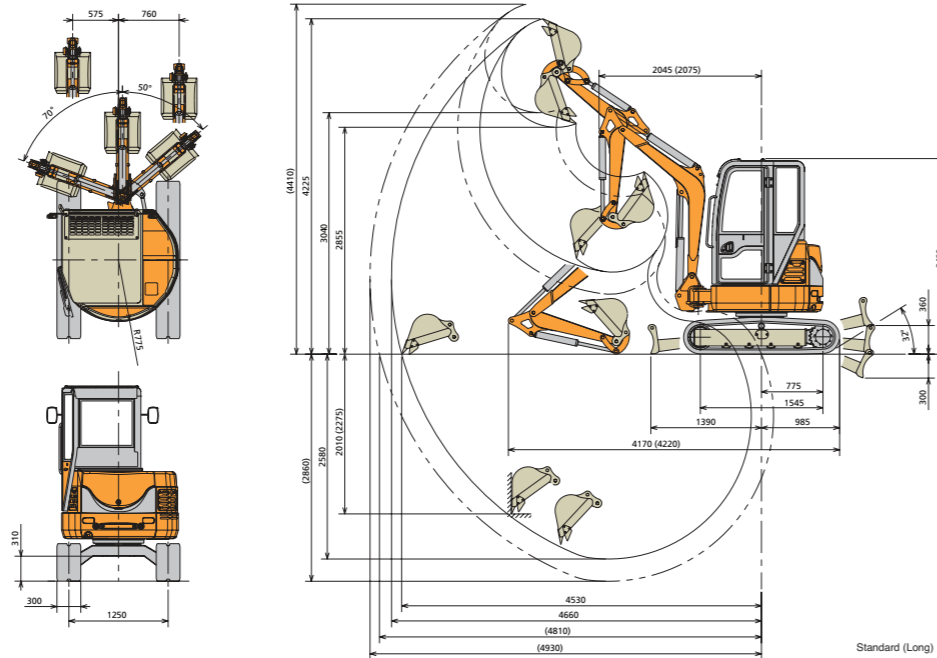

Specification

Machine weight (Cab - Rubber Tracks / Cab - Steel Tracks)	kg	2690 / 2760
Dimension (length / width / height)	mm	4170 (4220) / 1550 / 2460
Dozer blade dimensions (width / height)	mm	1550 / 290
Standard bucket (capacity / width)	m³/mm	0.07 / 450
Noise Level	LwA/LpA	93/78
Engine	Model	KUBOTA D1105-E3B
	Displacement	cc 1123
	Rated power	14.4kW / 19.6ps / 2400 rpm
	Fuel tank capacity	litres 31
Working Range	Max. digging depth (Std / Long)	mm 2580 / 2860
	Max. digging height (Std / Long)	mm 2855 / 3040
	Max. dumping height (Std / Long)	mm 3735 / 3925
	Max. vertical digging depth (Std / Long)	mm 2010 / 2275
	Max. digging radius (Std / Long)	mm 4660 / 4930
	Max. reach at ground (Std / Long)	mm 4530 / 4810
	Min. turning radius front (Std / Long)	mm 2045 / 2075
	Rear turning radius	mm 775
	Min. turning radius swing (Std / Long)	mm 1685 / 1715
	Boom swing angle (L / R)	degrees L70 / R50
Performance	Max. digging power Bucket / Arm (Std / Long)	kN 21.6 / 14.4 (21.6 / 14.1)
	Travelling speed (low / high)	km/h 2.2 / 4.1
	Slew speed	min⁻¹ 11.0
Hydraulic System	Pump	Type - Piston 2 + Gear 2
		Oil flow quantity litres/min 33.6 / 33.6 / 22.8 / 6
	PTO	Oil flow quantity litres/min 56.4
	Main relief pressure	MPa 21.6 / 21.6 / 17.2
	Hyd. tank capacity	litres 35

Lifting Capacity (kgf) Standard Arm, Cab

Lifting point Height (m)	Lifting point radius (3m)			Lifting point radius (3.5m)			m
	Blade Down	Blade Up	Over-side	Blade Down	Blade Up	Over-side	
2.0	629	503	428	611	385	328	3.8
0.0	1014	459	386	811	362	306	3.8
-1.0	920	462	389	-	-	-	3.2



www.hanixeuropa.com



Hanix Europe Limited

Unit 6, The Gateway Centre, Coronation Road, Cressex Business Park
High Wycombe, Buckinghamshire HP12 3SU. United Kingdom

Tel: +44 (0)1494 429040 Fax: +44 (0)1494 429059
Email: sales@hanixeuropa.com

H27DR

Zero-tail swing excavator with high breakout force and exceptional digging performance



Quick & Easy Access

- Fully-opening engine cover provides easy access for daily checks.
- Enlarged service covers and detachable counterweight for easy serviceability.
- Control valve block is side positioned for direct access.
- Connectors on auxiliary lines enable quick change of attachments without the need for stop valves.
- Standard bucket pins allow use of existing equipment.



Low Environmental Impact

- Fuel efficient Kubota engine improves combustion efficiency and reduces exhaust emissions.
- Emissions conform to Stage III A (EU)/ Interim Tier 4 (EPA) regulations.
- Auto idling system as standard.
- Low noise and vibration.



Maximum Operator Comfort

- Spacious, full vision cab for easy operator access and good all-round visibility.
- Joystick operation provides precision control and increased leg room.
- Fully adjustable fabric seat is linked with joysticks.
- Electronic cluster meter is attached to front of joystick for quick attention and clear vision.
- 3-speed heater / defroster or optional Air Conditioning / De-humidifier.
- Fully opening 'up-and-over' windscreen with removable lower section.
- Short pitch rubber tracks reduce travelling noise and vibration.



The Hanix H27DR is a tough and dependable compact mini-excavator designed to work in tight spaces.

Outstanding reach and digging depth, together with zero-tail swing, makes the H27DR ideally suited for tougher jobs in tight situations. Its large lower chassis and tracks provide that extra stability and balance when digging and a powerful Kubota engine, combined with an efficient double-acting hydraulic system, delivers smooth machine power for all operations.

Better in Tight Situations

- Zero-tail swing with long track arms and wide track bed for extra stability.
- Excellent all round vision for greater safety.
- Safe to operate close to walls or obstructions without risk of damage to the tail of the machine.
- Zero-tail reduces the possibility of accidents occurring behind the operator.
- Two-speed travel and straight line tracking.



Better Performance

- Wider operating range and stronger breakout force with greater stability.
- Low fuel consumption, saves on fuel costs.
- Large lower chassis and wide track bed for extra stability and balance.
- Switch between low and high speed travel at the touch of a button.

HANIX
MINI EXCAVATORS