

# DYNAPAC

Part of the Atlas Copco Group

## F121-4W/ D Wheeled pavers



### Technical data

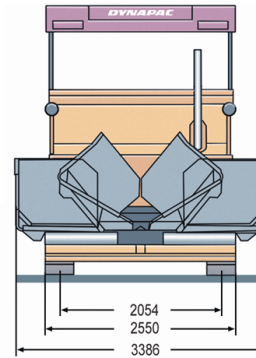
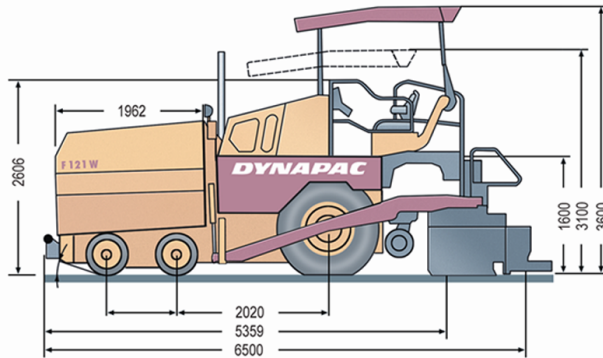

Dimensions	F121-4W/ D
Basic width	2.55 m
Working width, hydraulic extendable	5.10 m
Working width, maximum (incl. extension boxes)	6.60 m
Working width, minimum (with reducing shoe)	2 m
Masses	
Weight	17 t
Capacity	
Placement thickness (max)	300 mm
Theoretical placement capacity	600 t/ h
Undercarriage	
Drive wheels	2 x 14.00R-25
Front wheels	560 / 100-410
Final drive	Hydrostatic, for all functions
Turning radius (inside)	2,800 mm
Material hopper	
Capacity	13 t (5.9 m <sup>3</sup> )
Dumping height (center/ outside)	520 mm / 600 mm
Hopper width, internal	3,386 mm
Traction	
Paving speed	0 - 29 m/ min
Transport speed	19.5 km/ h
Engine	
Manufacturer/ Model	Deutz TCD2013L06V
Rated power	120 kW (163 hp) @ 1,800 rpm
Electrical system	24V
Emissions according to	EU/3A
Conveyor	
Conveyor type	Dual bar feeder
Conveyor width	600 mm
Conveyor control	Proportional speed control, both sides driven independently
Auger	
Auger diameter	380 mm
Auger control	Proportional speed control. Left and right augers to be controlled separately. Reversible direction of rotation.

Find your local dealer at [www.dynapac.com](http://www.dynapac.com)

We reserve the right to change specifications without notice. Photos and illustrations do not always show standard versions of machines. The above information is a general description only, all informations are supplied without liability.