

Dynapac CA510D

Single drum vibratory rollers

Atlas Copco



Technical data



Masses

Max. operating mass	18,500 kg
Operating mass (incl. ROPS)	18,300 kg
Module mass (front/rear)	12,300/6,000 kg



Traction

Tyre size (8 ply)	23,1x26
Theor. gradeability	43 %
Vertical oscillation	±9°



Compaction

Centrifugal force (high/low amplitude)	317/231 kN
Nominal amplitude (high/low)	1.8/1.1 mm
Static linear load	58 kg/cm
Vibration frequency (high/low amplitude)	29/31 Hz



Engine

Manufacturer/Model	Cummins B5.9-VE-TAA (*)
Type	Water cooled turbo Diesel with After Cooler
Rated power, SAE J1995	129 kW (173 hp) @ 2,200 rpm
Fuel tank capacity	320 l



Hydraulic system

Driving	Axial piston pump with variable displacement. Axial piston motor (2) with variable displacement.
Service brake	Hydrostatic in forward and reverse lever.
Steering	Gear pump with constant displacement.
Vibration	Axial piston pump with variable displacement. Axial piston motor with constant displacement.
Parking/ Emergency brake	Failsafe multidisc brake in drum gear box and in rear axle.

Find us locally at www.atlascopco.com

We reserve the right to change specifications without notice. Photos and illustrations do not always show standard versions of machines. The above information is a general description only, all informations are supplied without liability.

Dynapac CA510D

Single drum vibratory rollers



Technical data

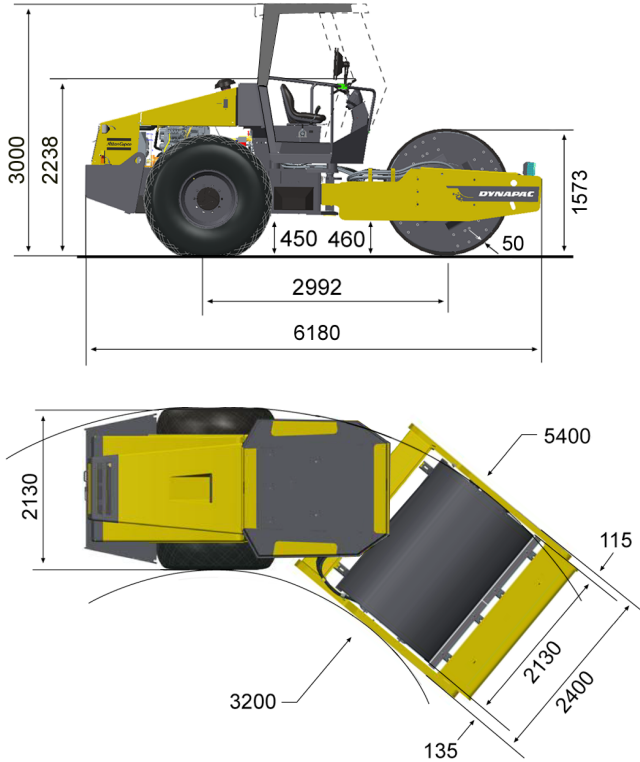

Find us locally at www.atlascopco.com

We reserve the right to change specifications without notice. Photos and illustrations do not always show standard versions of machines. The above information is a general description only, all informations are supplied without liability.